

SPHERE PACKING: BACH

BY RAFAEL LOZANO-HEMMER - BORUSAN'S EDITION



TABLE OF CONTENTS

GENERAL IMPORTANT INFORMATION	3
Technique	4
Description	4
Operation	5
Maintenance	6
Placement Instructions	9
DETAILED TECHNICAL INFORMATION	12
Normal Software Operation	13
Manual Software Calibration	16
Software Shortcuts	22
Network Settings	23
Remote Access to Artwork's Computer	24
Preliminary Troubleshooting Steps	25
Troubleshooting Assistance	29
Support (Contact Us)	30
APPENDIX I - INSTALLATION	31
Description of Components	32
Wiring Diagrams and Connections	36
APPENDIX II - TECHNICAL DATA SHEETS	39
Metal Skeleton	40
Wood Slats	41
Speaker Brackets	42
Speakers	47
microSD Cards	49
Ethernet Cables	50
90 degrees Ethernet Couplers	50
Patchbays (controller boards and power supplies)	51
Enttec Storm8	54
Computer and Software	59
APPENDIX III - PLAN VIEWS: SPHERE AND COMPONENTS	60
General Dimensions	61
Nomenclature of the Sphere Sections	62
Sphere Eighths and Dome	68
Dollies	77
Patchbays - Components Details	80

Speakers: Position in Sphere, Label, Controller Connection and Cable Length	90
Controller Patching Information	119
APPENDIX IV - ASSEMBLY OF SPHERE	134
Required tools	135
Important Notes Before Beginning Assembly	135
Uncrating	135
Installing Bottom 4 pieces	139
Installing Top 4 pieces	141
Dome	145
APPENDIX V - DISMANTLING OF SPHERE	155
Before beginning De-Install	155
Decabling	156
Disassembling and Rigging	163
Top Sections	163
Right and Left Sections from the Door	167
Right and Left Sections from the Spine	171
Bottom Sections	174
Crating after dismantling the artwork	177
APPENDIX VI - REPAIRS AND OTHER MANIPULATIONS	178
Removing a speaker from a slat	179
Reconditioning a wood slat	179
Replacing a wood slat	180
Fixing a Ethernet cable RJ45 hook clip	184
APPENDIX VII - CRATES AND PACKING	185
Crate RLH-W198	187
Crate RLH-W199	187
Crate RLH-W200	187
Crate RLH-W201	187
Crate RLH-W202	187
Crate RLH-W203	188
Crate RLH-W204	188
Crate RLH-W205	188
Crate RLH-W206	188
Crate RLH-W207	189
Crate RLH-W208	189

GENERAL IMPORTANT INFORMATION

This short section must be read for proper operation.

SPHERE PACKING: BACH (2018)

BY RAFAEL LOZANO-HEMMER

Technique

Aluminium and wood, 1,024 custom-made speakers, circuits, computer, display, patchbays, ethernet cabling.

Description

"Sphere Packing: Bach" is a 3m diameter sphere made out of aluminium and wood which supports an array of 1,024 loudspeakers each of which plays a different composition by Johann Sebastian Bach. The piece is designed to concentrate Bach's entire musical production in a dense multi-channel structure that visitors can enter.

At any given point, all compositions play-back simultaneously creating a polyvocal and complex sound environment focused in the centre of the sphere; from time to time the speakers are gradually silenced in waves to highlight one speaker playing a single composition.

All speakers have a small amber LED light which helps visitors get visual feedback on which speakers are operating. The piece includes a backstage where 11 km of cables connect to a bespoke patchbay controlled by custom software that activates the speakers in sequences of geometrical eclipses.

The piece is the culmination of the "Sphere Packing" series of sound sculptures that Rafael Lozano-Hemmer has been making since 2013. The fact that Bach was the most prolific of the 17 composers in the series, called for a room-like immersive environment instead of a sculpture. As a master of counterpoint, layering Bach's compositions, yields a particularly interesting experiment in musical turbulence.

Operation

Please refer to [Appendix I - Installation](#) for detailed system information and wiring diagram.

1. Connect the computer and the patchbays to electrical power. Use the supplied power cables. Use mechanical timers to apply power in a staggered fashion to the patch bays: giving power to the first patchbay, followed by the next patchbay 30 seconds after, and finally the last patchbay 30 seconds after the second.
1. To turn the piece ON, press the power button on the computer for one second, then release it. Important note: *please do not push the button again as this will shut down the piece.* Wait at least two minutes before pressing it again, as the computer might need this long to reboot. After two minutes (or less), you should see the piece. The app **bachSphere** will start automatically once the computer is done booting up.
2. To turn the piece OFF, press the power button on the side of the small box, or the computer button.
3. If the piece doesn't start within two minutes, try turning on the piece again. If it still doesn't turn on, then hold the power button all the way down for 10 seconds. Then, wait at least three seconds, then press the power button all the way down for one second, and you should be up and running again.

Note: the artwork could be set so the computer automatically turns ON at a specific moment of the day and OFF at another time, via the macOS power scheduler.

Maintenance

A feather duster or a hand duster (like a Swiffer) is recommended for undusting the following components of the sphere: the speakers, their brackets and the ethernet cables.



We recommend undusting the wood slats and metal structure with a microfiber cloth as the edge of the slats are very fragile so no pressure should be applied. Slightly dampen said microfiber cloth to remove marks and residues from the wood slats and speakers.



Use a compressed-gas duster meant for computers to get the dust off the controllers and the end of the ethernet cables. **Warning:** do not use an industrial compressor because it can leak oil and water. Do not use a microfiber cloth or a duster as it could damage the pins on the circuit board.



It is easier to reach the controller with the compressed-gas duster from behind like shown in the picture below.



Finally, to clean the ethernet cables running between the sphere to the controllers, first use a vacuum cleaner to get the excess dust on the bundles. Then, you should use a compressed-gas duster to get in the spots the vacuum cannot reach.

We recommend cleaning the entire piece every two months at least.

It is also recommended to do a frequent inspection of the different components.

Check if any of the speakers were moved by visitors; the speakers should not point to the sphere's center, but should be perpendicular to the wooden tablet. Gently move the speakers and the brackets back into place, if they have been moved.

Check that none of the speakers' front grills have fallen off. If they did, simply glue them back into place with Krazy Glue.

Check that all of the speakers have their LEDs illuminated when in play mode. If not, re-adjust the LED, because it might have become loose.

Ensure that all of the speakers play the correct audio file. Refer to the [preliminary troubleshooting steps](#) for details on how to change microSD cards or the entire speaker.

Do not touch the electronics in the patch bay, as they are sensitive to electrostatic discharges.

Placement Instructions

Please revise these general points before assembling or dismantling the piece:

- the corners of the shelves are fragile and can potentially get caught in fabric;
- add foam blocks on each shelf corner near centre of the sphere (backspine), where all the cables meet, so the weight of cabling doesn't press on and damage the shelves corners;
- do not pull on cables: always leave them loose to protect the speaker connector or patchbay connectors;
- make sure each cable is connected and engaged to their respective brackets;
- be gentle when unplugging the cables from the speakers: gently hold the front and back of each speaker before disconnecting the cable by pitching its locking tab;
- the connectors have a fragile plastic extension sticking out that has a tendency to get caught onto things. Be careful - if it breaks, you need to replace the entire cable. As a precautionary measure, we have incorporated a **transparent plastic tubing** onto them, which can be taken off only when the time comes to plug the cables to the patchbays.

Detailed information about the assembly of the artwork can be retrieved in the [APPENDIX III - ASSEMBLY OF SPHERE.](#)

Detailed information about the dismantling of the artwork can be retrieved in the [APPENDIX IV - DISMANTLING OF SPHERE.](#)

The artwork is composed of two parts. The first part is the sphere itself and the second part includes the three patchbays. A wall separates these two parts and all cables pass through a hole in the wall. Such a wall between the sphere and the patchbays is optional.



Positions of the elements at the Musée d'Art Contemporain de Montréal, Canada.



Sphere separated from patchbays by wall (during the WIP)

The hole's diameter is 35 cm (14 inches). The position of this hole is measured at **150 cm** from the center of the wall to the floor and is centered with the sphere. This is achieved simply by creating a masking tape line on the ground from the **center vertical aluminum part** of the sphere onto the wall.



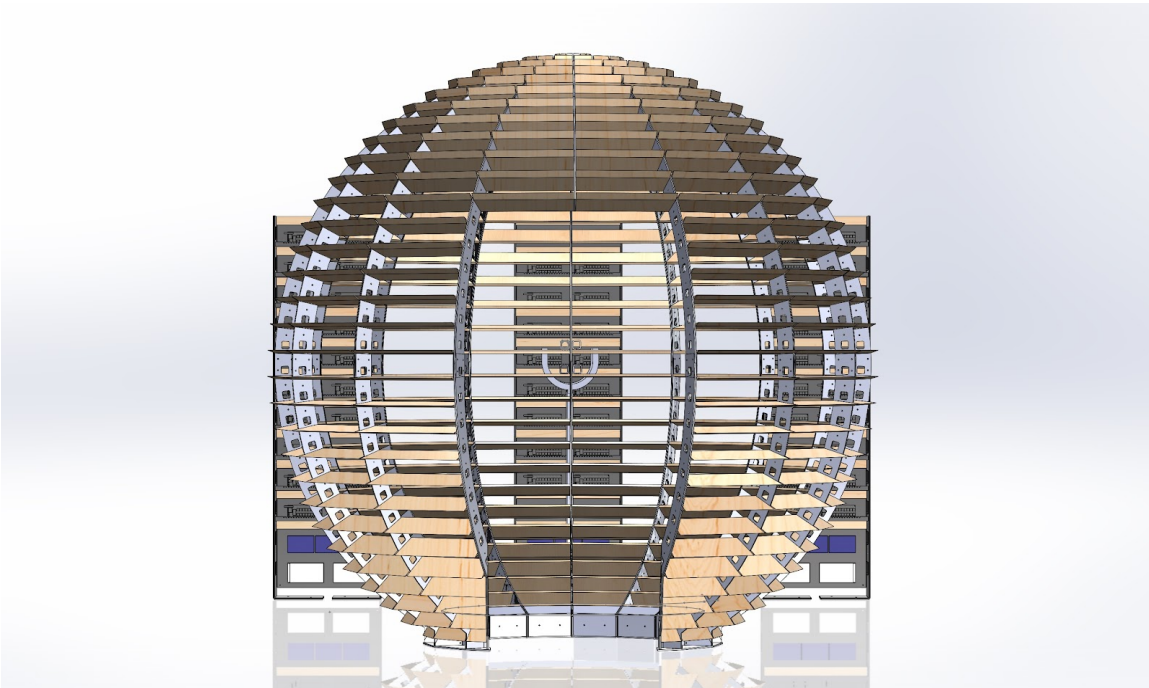
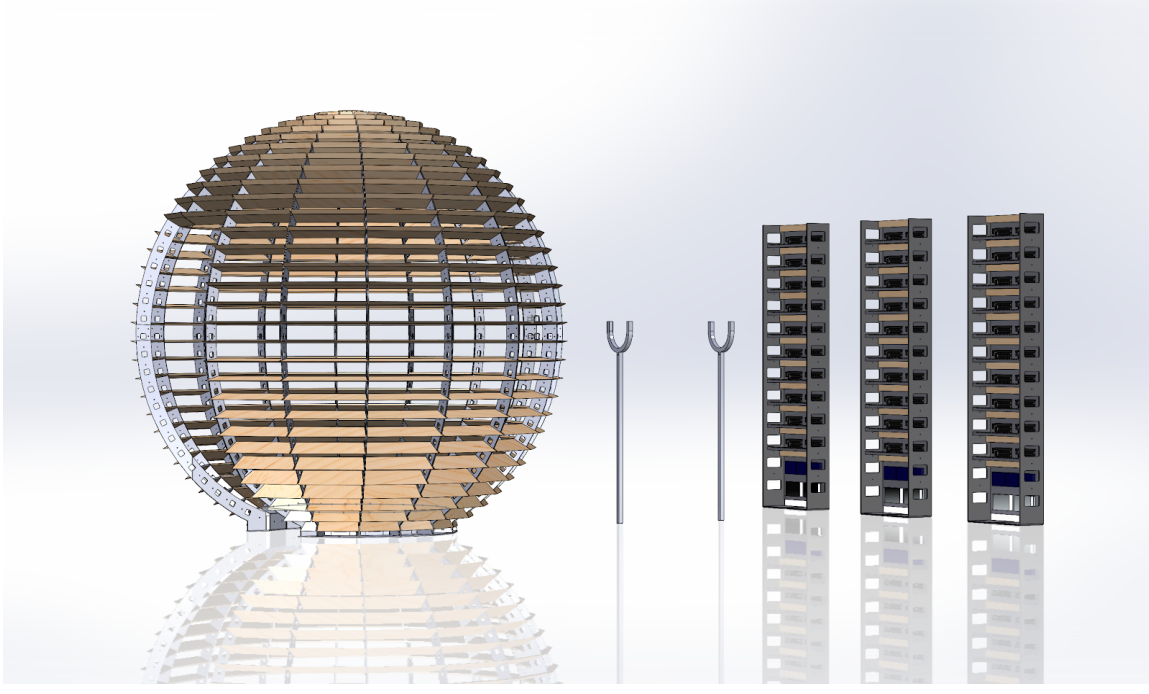

Sequencing example of Sphere with patchbays. This configuration is without a wall, in which case, two cable holders would be needed. In the case of a separating wall, only one cable holder on the patch bay's side of the wall is necessary.

DETAILED TECHNICAL INFORMATION

Normal Software Operation

When the software starts and the patch bays have power, all the speakers receive a reset command which will bring their audio tracks to the start position, ensuring that audio track #1 is selected and the volume is set to a default level.

Then, the volume will increase to almost maximum, while all speakers play back the music.

The LEDs on each speaker should be illuminated when the speakers are in play mode and the LEDs should be off when they are in pause mode.



Now the software will start in **wedge mode**. A wedge shaped 3D object appears on the screen and slowly pierces the 3D model of the sphere. All speakers on that sphere that are located inside the wedge will be set to play mode. All other speakers should be off.

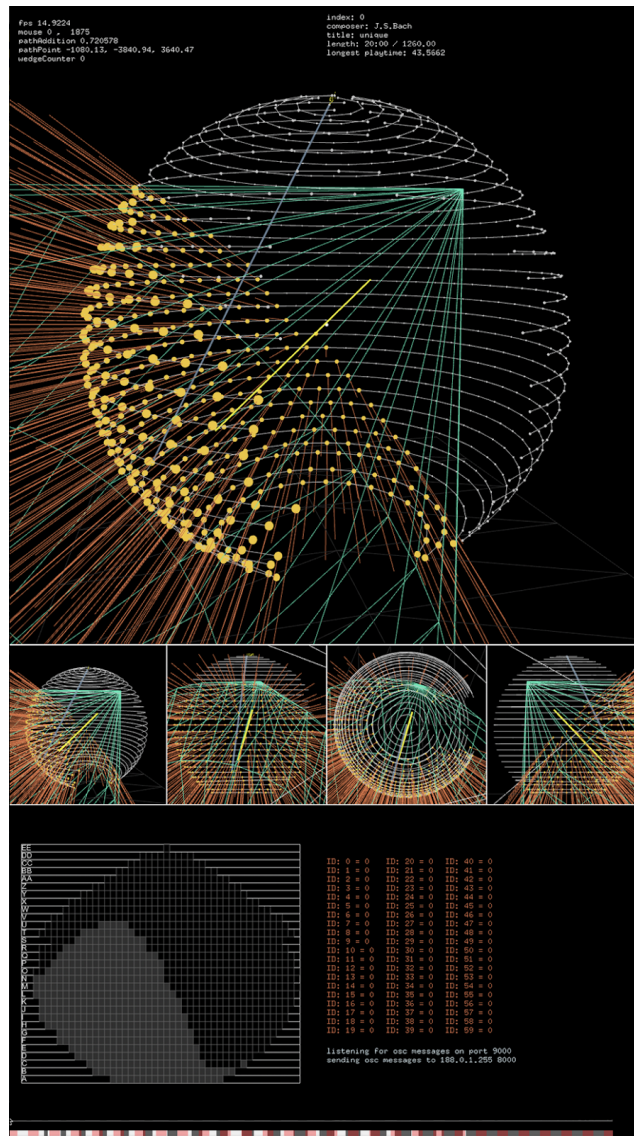

The wedge slowly takes over the whole sphere until all speakers are in play mode. For a few seconds all speakers will be playing and then slowly the wedge will exit the sphere. Fewer and fewer speakers will be in play mode until only one speaker remains playing the music.

The software will go through five cycles of the wedge mode, taking about 45 seconds each. During the final cycle, when all speakers are playing music, a reset command will be sent to all speakers. This means that for a short moment, all speakers will stop playing music, and will reset to their start position and will slowly increase their volume.

After this reset, all the wedges will exit the sphere and switch to **spotlight mode**. In this mode, a long cuboid is intersecting with the 3D sphere, instead of the wedge. This will cause a small group of speakers to be in play mode.

Over time, the cuboid will move around and highlight different sections of the sphere. It will also grow in size, then shrink again. Spotlight mode will take about one minute.

After this, the whole cycle starts again, starting with the wedge mode again.

During the normal operation of the artwork, each speaker plays a unique Bach composition. But when desired and as per discussed with studio's staff, the collection or exhibition staff can switch the artwork to **performance mode**. In this mode, all speakers will play the same audio track, only two wedge cycles are performed, and the spotlight ends with all speakers in play mode.

Manual Software Calibration

Pressing the G key will make the GUI appear and display the different settings used to run the artwork. These settings are typically modified only when the artwork is initially set up in its location. All GUI elements should remain as indicated below. [Contact the studio](#) prior to changing them.

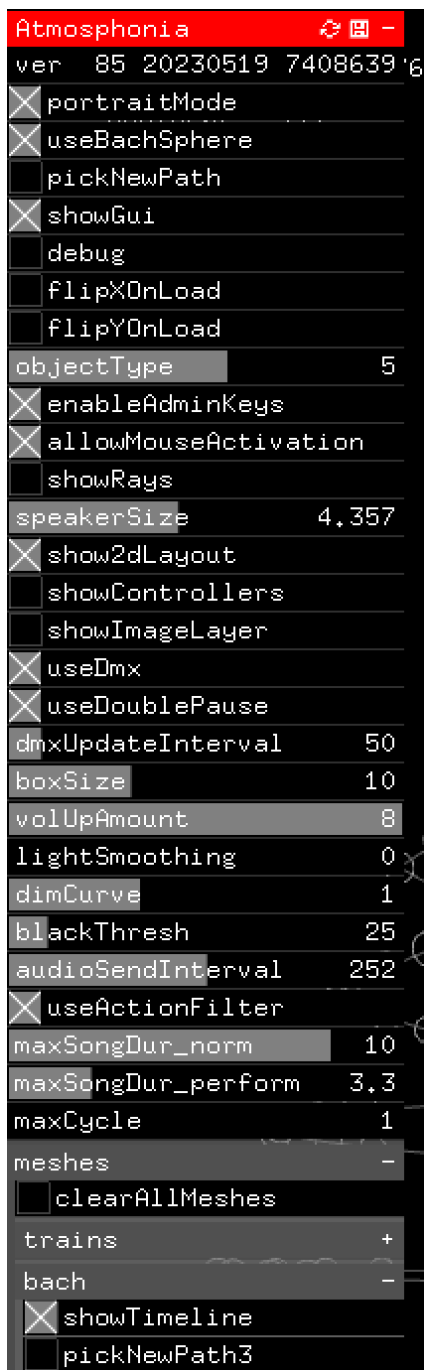

ver: displays the software version number running of your computer

portraitMode: deselect this field if the artist wants the display to be mounted in landscape mode

useBachSphere: do not touch, leave checked

pickNewPath: when clicked by the user, causes the 3d object to move through the sphere again with a new path

showGui: clicking this will make the menu disappear

debug: Prints out extra information in the terminal

flipXOnLoad: do not touch

flipXOffLoad: do not touch

objectType: do not touch, value of 5 is needed for this setup

enableAdminKeys: allows access to some “advanced” keyboard shortcuts

allowMouseActivation: speakers can be set to play or pause mode by clicking on them in the 2D pyramid or 3D sphere view

showRays: Illustrates rays of light when speakers are lit up

speakerSize: sets how big the cubes representing the speakers are drawn in the 3D simulation

show2dLayout: shows the grid layout of all the speakers: helps to understand which speakers are together on which shelf

showControllers: do not touch

showImageLayer: do not touch

useDMX: needs to be checked to send DMX signal to controllers

useDoublePause: sometimes the speakers do not react to the pause signal: if selected then two pause messages are send out to fix this issue

dmxUpdateInterval: controls the speed at which DMX signal is sent, if data is sent too fast, some of that data is being missed by PCBs. Setting is tweaked for provided components, do not touch

boxSize: do not touch

volUpAmount: the default volume the piece is at on software start and after every new cycle start, no matter if someone used the keyboard’s volume up or volume down keys which only temporarily affect those volumes

wedgeScale	1328
minPathDist	332
beamScaleMin	0,7
beamScaleMax	6
PerfBeamMin	0,965625
PerfBeamMid	6
PerfBeamMax	0,50625
wedgeAmount_norm	7
wedgeAmount_perf	3
bUsePerformance	
performanceTrack	2
pTrack	
doAction	1
doStr	PLAYPAUSE
doLightLevel	200
undoAction	2
undoStr	PAUSE
undoLightLevel	0

lightSmoothing: while visible, this setting doesn't impact anything as this controls LED strips not present in Bach: do not touch

dimCurve: while visible, this setting doesn't impact anything: do not touch

blackTresh: while visible, this setting doesn't impact anything: do not touch

audioSendInterval: on teensy a short button press is 280ms, a long 800ms. button teensy also can queue 20 messages which mean we can send them via dmx faster but don't hear them applied right away: this slider sets how fast all those buffered audio messages are sent out

useActionFilter: if multiple pause and play messages are buffered the filter checks if there are doubles that can be removed to avoid sending useless data

maxSongDur_norm: used for normal mode, sets the maximum play duration, in minutes, before the system sends a reset signal

maxSongDur_perform: used for performance mode, sets the maximum play duration, in minutes, before the system sends a reset signal

maxCycle: for normal mode, after this many cycles we do a reset otherwise audio files end and go to next track

meshes: while visible, settings from this group don't impact anything: do not touch

train: while visible, this setting doesn't impact anything: do not touch

bach - showTimeline: shows the curves that are used for the 3d objects in and out motion path

bach - pickNewPath3: as pickNewPath, when clicked by the user, causes the 3d object to move through the sphere again with a new path

wedgeScale: size of the 3D wedge objects that pierce the sphere. It needs to be large enough to encompass all speakers.

minPathDist: the minimum distance to the next speaker that gets picked as the next wedge destination.

beamScaleMin: the smallest size the spotlight can have.

beamScaleMax: the largest size of the spotlight.

PerfDeamMin: sets the minimal size of the different stages of the moving beam animation

PerfBeamMid: sets the midpoint size of the different stages of the moving beam animation

PerfBeamMax: sets the maximal size of the different stages of the moving beam animation

wedgeAmount_norm: for in normal mode, determines how many wedge cycles are shown during normal mode, before we see the beam animation

wedgeAmount_perf: for performance mode, determines how many wedge cycles are shown during normal mode, before we see the beam animation

bUsePerformance: activates Performance Mode

performanceTrack: selects track to be played in performance mode

pTrack: selects the common track from the SD card to be played back in performance mode

doAction: controls the state in which the speaker should be when it gets activated: selected value sets if speakers will be in play mode, volume up or next track or others. Most of the time this value means Play

doStr: related to doStr: puts word to the selected value

doLightLevel: while visible, this setting doesn't impact anything: do not touch

undoAction: controls the state in which the speaker should be when it gets un-activated: selected value sets if speakers will be in play mode, volume up or next track or others. Most of the time this value means Pause

undoStr: related to undoStr: puts word to the selected value

undoLightLevel: while visible, this setting doesn't impact anything: do not touch



The “Cars” section of the menu isn’t impacting the software: avoid changing any value.

Scene camera is used to toggle on or off different views in the software render.

- showMainCam:** shows large sphere image
- showSideCam:** shows smaller sphere on sidebar
- moveByMouse:** allows mouse to move large sphere
- relativeY:** do not touch
- bLoadCamPos:** loads the final sphere position
- bSaveCamPos:** saves the current sphere position and uses it as default

allSpeaker, used for debugging, allows you to manually trigger a selection of speakers and control them by sending specific signal(s) to selected speakers.

controller: while visible, this setting doesn’t impact anything: do not touch

row: while visible, this setting doesn’t impact anything: do not touch

- pauseAll:** click to pause
- playPauseAll:** click to play, then pause
- bResetAll:** click to send a reset signal
- bResetPlayAll:** click to send a reset signal, then play
- bNextAll:** click to skip to next track
- bBackAll:** click to return to previous track
- bVolUpAll:** click to increase volume by one increment
- bVolDownAll:** click to decrease volume by one increment
- bVolFadeUpAll:** click to increase volume gradually up to volUpAmount value
- bVolFadeDownAll:** click to decrease volume gradually
- bResetAllAndVOLUP:** click to send a reset signal, increase to the volUpAmount value
- minBrightness:** while visible, this setting doesn’t impact anything: do not touch
- maxBrightness:** while visible, this setting doesn’t impact anything: do not touch
- enableAudio:** enables audio output while running your tests

showDMX: when checked, all DMX channel’ signal values are drawn as a bar to visualize the final output

showFrames: when checked, groups the above bar per controllers

This is what one span looks like under spotlight mode. Over the duration of X seconds the white point travels from left to right: the resulting Y value refers to the location of the spotlight along the preset motion path. The curve has been calibrated to render specific reaction, please do not touch the settings.

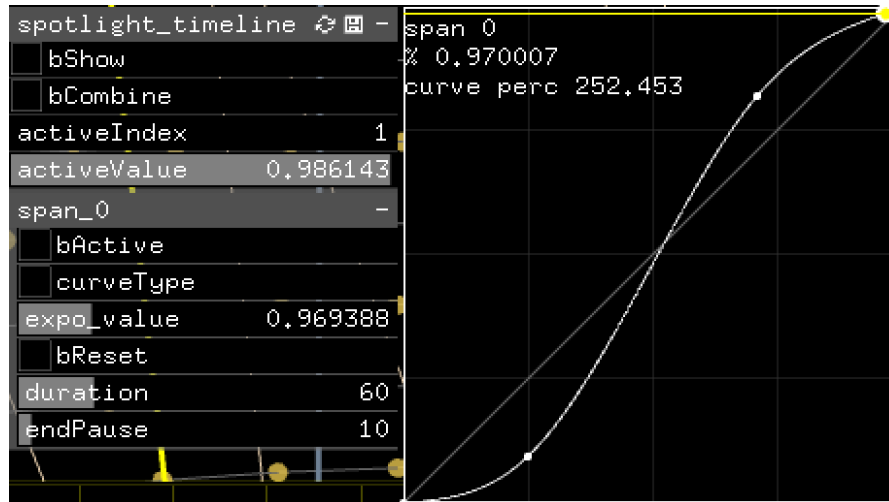

This is what one span looks like under wedge mode, where the animation travels from one side of the sphere to the centre of it (span_0), then from center towards the exit point (span_1). Over the duration of X seconds the white point travels from left to right: the resulting Y refers to the location of the wedge along the preset motion path. The curves have been calibrated to render specific reactions, please do not touch the settings.

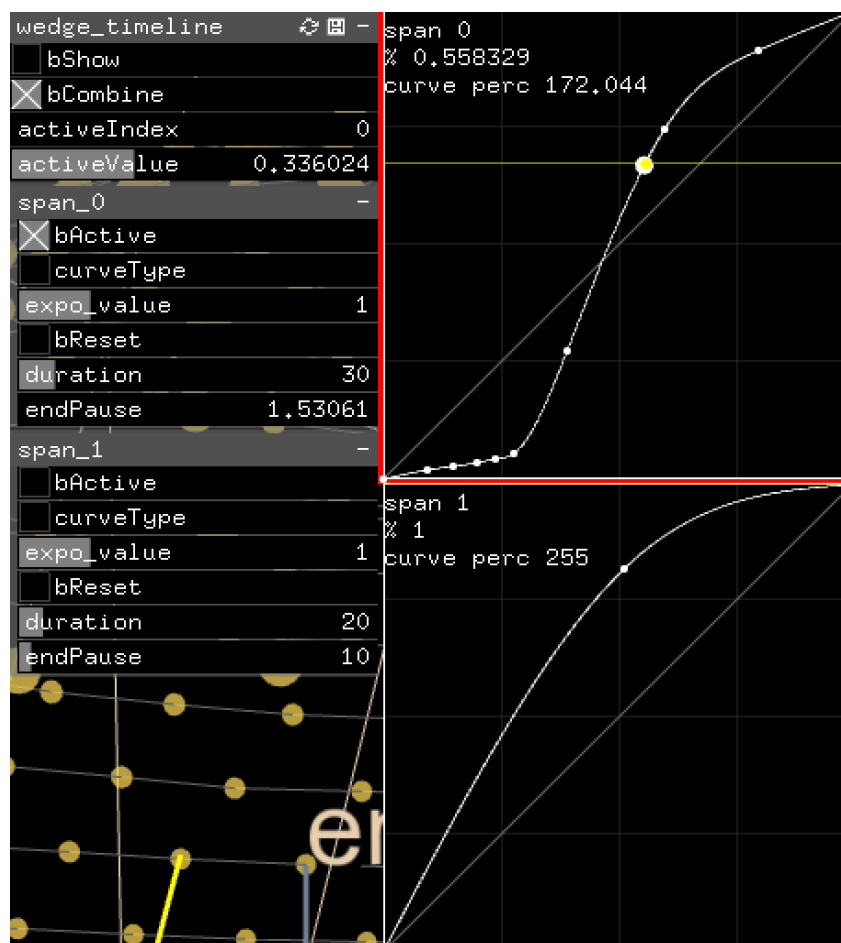

Software Shortcuts

The following keyboard shortcuts allow you to trigger different modes or reactions.

Regular shortcuts	
G	Shows or hided the GUI
M	Hides the mouse cursor
F	Toggles the fullscreen mode
X	Tells all speakers to reset: this causes the speaker to automatically go to beginning of track #1, reset the volume to default level 7 and put the speaker in play mode. This can also be done on the speaker PCB by holding down the Back key for 2 seconds.
Z	Switches the software from Normal mode to Performance mode and vice versa.
Admin shortcuts	
1,2,3,4,5,6,7	Different 3D shapes will appear and intersect with the sphere, some of which are controlled by the mouse. Key 5 brings up the wedge.
0 (zero)	No 3D shape will be present. This mode is great for debugging.
N	Picks a new path for the wedge to travel on.
O	Increases the volume of all speakers by one increment.
P	Decreases the volume of all speakers by one increment.
S	Tries to sync all files. This is an experimental feature.

Network Settings

The controllers used by the artwork receive signals from the software via network communication. To allow this, the computer needs to be set with some specific network configurations for the Ethernet adapter.

Such configuration is done via: System Preferences -> Network -> Ethernet.

Parameter	Value
Configure IPv4	Manually
IP Address	10.0.7.88
Subnet Mask	255.255.255.0

Remote Access to Artwork's Computer

There is a software installed on the computer running this artwork that allows the studio to connect remotely to the artwork. This feature is helpful when you require assistance from the studio, as we can remotely connect to it, do a quick inspection, and do a debugging session of your components, if needed. In order to enable this feature, the computer has to be connected to the internet at all times. Depending on the computer's operating system (Windows 7/8/10, OSX), the procedure to set the computer online will vary. Please look online for tutorials, if necessary.

Preliminary Troubleshooting Steps

A LED on one of the speakers is blinking.

This means that the speaker is in **radio seek mode**. These speakers also have a FM radio function, and if the **play** button is held for too long by the controller PCB, it will enter the **radio mode**. A blinking LED light could also indicate that the speaker did not recognize the microSD card; either there is no card or the card is corrupted.

First, try to cycle the power on the speaker by unplugging and replugging the RJ45 connector on the back of the speaker. Wait a few moments to see if the software correctly turns the speaker on or off.

If the LED flashes **ON** 3 seconds, then **OFF** 3 seconds, the problem is the microSD card. Ensure the microSD card is present and inserted correctly and test again. If the issue still happens, replace the microSD with a new card with the correct sound files on it. Refer to the microSD Cards section for more information. To proceed to a microSD card swap, locate the card slot on the side of the speaker. With your finger nail, press on it slightly. The SD card should pop out. The card should have a label on it that matches the label on the cat5e cable. This label will help you locate the correct set of audio files that need to be copied onto a new microSD card.

If after replacing the microSD card you have the same issue, the speaker's card reader might be faulty, replacing the speaker itself might fix the issue.

If after replacing the speaker for a new one, there's still an issue, disconnect and reconnect the cable on the speaker and make sure it clicks in, locate the other end of the cable and also disconnect and reconnect it from the controller board and make sure it clicks in.

A speaker plays audio from a radio station.

This is perhaps caused by the same reason described above.

A LED on top of a speaker is off all the time.

The most likely reason for this is that the LED is loose. After making sure that the speaker is in **play mode**, try pushing the LED back into its socket. You can also try a new LED. Make sure to respect the polarity.



When looking at it from the front, the negative entry (-) is on the left and the positive (+) entry is on the right.

There is a glitch in one of the speaker's audio tracks.

This means part of the audio file on the microSD card is corrupted. The only way to fix this is to use a new card with the correct audio files on it.

The software is not controlling the patchbay.

All three patchbays should be daisy chained, meaning a series of network cables should jump from one 24-port network switch to the next, and the final network switch should be connected to the computer.

Also, make sure that the computer's IP address for its ethernet connection is **10.0.7.88**,
Subnet Mask: 255.255.255.0.

One-third of all the speakers are off.

This means that one of the patch bays is not receiving power.

About 100 (18 x 6 or 18 x 7) consecutive speakers are off.

This means that one of the three power supplies at the bottom of each bay is either not receiving power, or is broken, or its connection to the DC power terminal is loose.

A group of 24 consecutive speakers are off

This means that a controller board is either off or broken. To fix it, locate first the relevant board by finding its ID of one of the faulty speakers (on the cable label), then in the software, hover mouse over the point of the speaker in the sphere 3D model: a popup will appear with info on the speaker. The controller index will be between 0 and 42.

First try cycling power: unplug and replug the barrel jack power connector on the left-most side of the faulty board. Once the board powers on, press the **play/pause** button to test that the speakers turn on and respond. If speakers do not respond, replace the Teensy board and test again. If the issue persists, replace the board.

If speakers respond to pressing the physical button on the board but not to DMX messages, replace the ethernet cables connecting the board with other boards and test again. If the issue persists, replace the board.

Part of one row is always ON or OFF.

This means that the computer communication with one of the PCBs in the patchbay stopped working. Take a look at the artwork's screen. Here, you should see one of the IDs displayed in red, which means this specific PCB can't be communicated with. Find the patchbay that this PCB is housed in and either cycle the power for the whole bay, or cycle the power for this PCB only, or try pressing the reset button on the PCB.

Consult the pictures below as reference.

Please note that the last three PCBs (57,58,59) are not used and act as spares. (So, the fact that in this picture **ID: 58** is red should not worry you.)

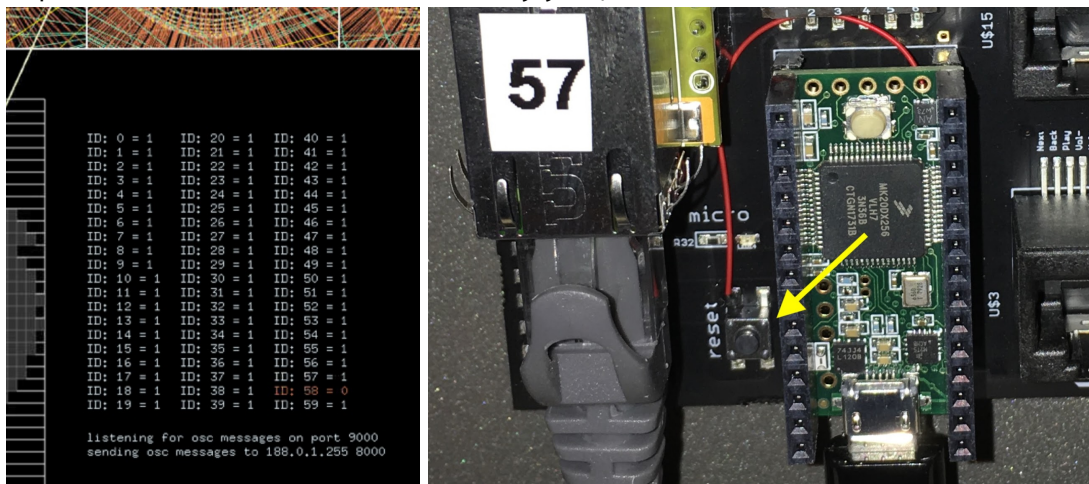

The front grill of a speaker fell off and is hanging by a wire.

Add a small amount of crazy or super glue on the inside of the speaker body and press the grill back into place. Be careful to not pinch the cables soldered to the speaker.

A speaker is loose and is not mounted on its bracket.

The speaker is fixed to the black metal bracket with double sided tape. If you need extra tape, please make sure it is not white or bright, otherwise the tape may be visible from the side.

A bracket holding a speaker in place is bent or is pointing in the wrong direction.

Please rotate or carefully bend the whole bracket back into the right orientation. Be careful; the metal bracket is only attached to the wooden shelf with one wood screw. If this screw breaks out of the wood, it will be very difficult to repair.

One RJ45 port on the PCB is broken. Not all speaker functions work.

It might be that one of the 18 ports on the PCB is broken. Each port is responsible for five different speaker functions: **volume up**, **volume down**, **next track**, **reset**, and **play+pause**. If the micro chip that connects to the RJ45 connector has a problem, or the RJ45 connector itself has a loose connection, then one of these five functions might not reach the speaker.

In this case, you can unplug the cat5e cable from this port and use a port in one of the spare PCBs, such as PCB # 57, # 58, #59.

Next, you need to tell the software that the cable with this specific label is located in this new port. To do this, open **output.txt** inside the **bachSphere/bin/data** folder. Find the location for your specific label.

For example:

CC; 28; CC07-J1; J; 1006; 7; 13; -275.129; 1256.46; -150.339;55; 16

Make a copy of this line and leave this line as-is. There is no need to delete it.

Now scroll down to the bottom of the text file. There you will find 22 unused ports.

Depending on which unused port you plugged the cat5e cable into, you now need to edit the label and XYZ information in this section.

For example:

XX; 31; A14-K1; K; 1036; 14; 22; 0; 1292.93; 0; 57; 10

Will become:

XX; 31; CC07-J1; J; 1036; 14; -275.129; 1256.46; -150.339; 0; 57; 10

Troubleshooting Assistance

Prior to contacting the Antimodular Studio with a problem about your artwork, please ensure that you went through the preliminary troubleshooting steps outlined in the previous section.

The troubleshooting process will vary depending on the problem. In order to make the process easier, it is recommended that you collect and send the following information to the studio:

- Date and time when the problem first happened;
- Description of the problem;
- Actions taken so far and conclusions;
- Detailed photographs (or videos) displaying the problem;
- Detailed photographs (or videos) of the suspected faulty component;
- Detailed photographs (or videos) of the whole artwork and its surroundings;
- Personnel involved.

Support (Contact Us)

If you would like support for the piece, please feel free to call Lozano-Hemmer's studio in Canada:

Antimodular Research
4462 rue Saint-Denis
Montréal, Québec, Canada
H2J 2L1
Tel 1-514-597-0917
info@antimodular.com
www.antimodular.com

APPENDIX I - INSTALLATION

Description of Components

This artwork requires the following components:

Component	Description
Metal skeleton	Frame for the sphere, hosting the wood slats.
Wood slat	Act as a shelf for the speakers.
Speaker bracket	Attaches speaker to the wood slat.
Speaker	Custom-made speaker that plays back a few compositions. Selection and play state depends on the software commands.
SD Card	Storing the different compositions specifically picked for a said speaker.
Ethernet cable	Carries signal from computer to controllers via network switches, then power and signal from controller to speaker
90 degrees Ethernet coupler	Used in some cases where the speaker has to be closer to the metal skeleton.
Controller board	Sends over the power and playback signals to the speakers.
Enttec Storm 8	Carries over the playback commands from the computer to the controllers.
Computer	Apple MacMini that runs the software that controls the whole artwork rendition and sends signals to the Storm8 unit.
Monitor	Used to control and display the software. Monitor can be shown or hidden.
Video cable	Connects the computer to the display.

Images of components, for consultation:

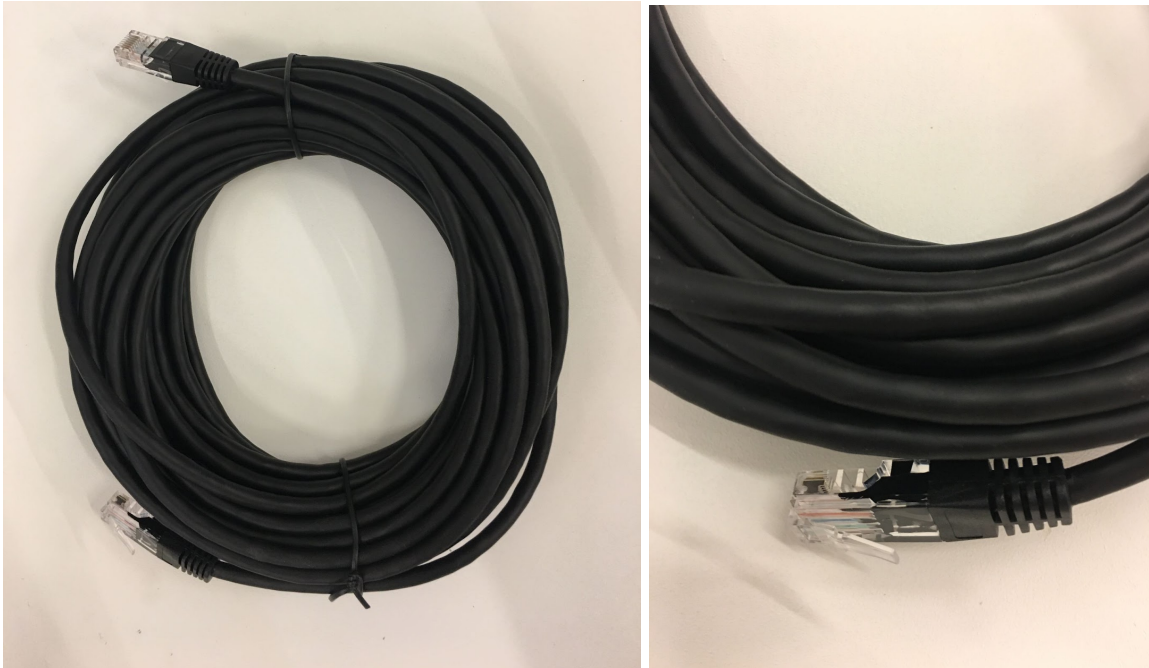
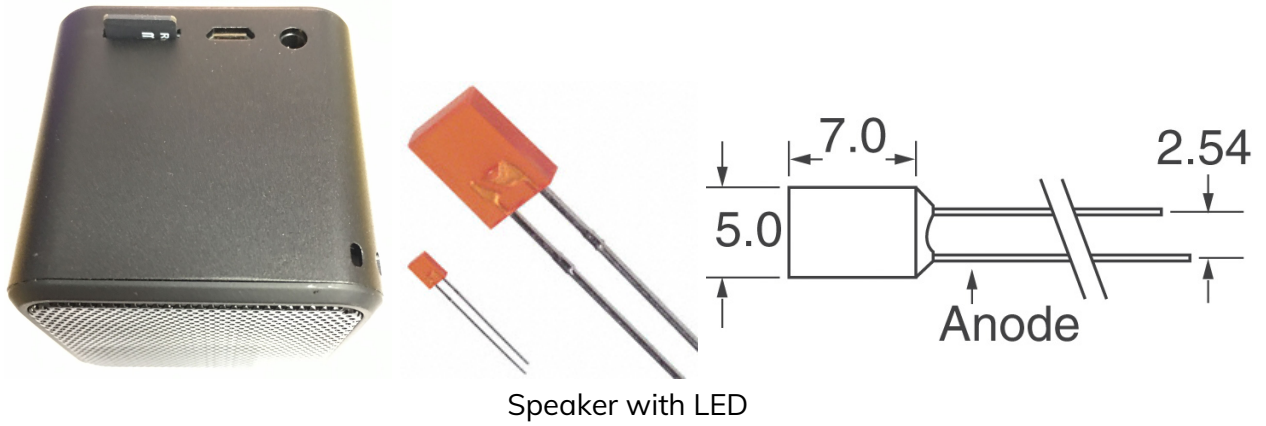

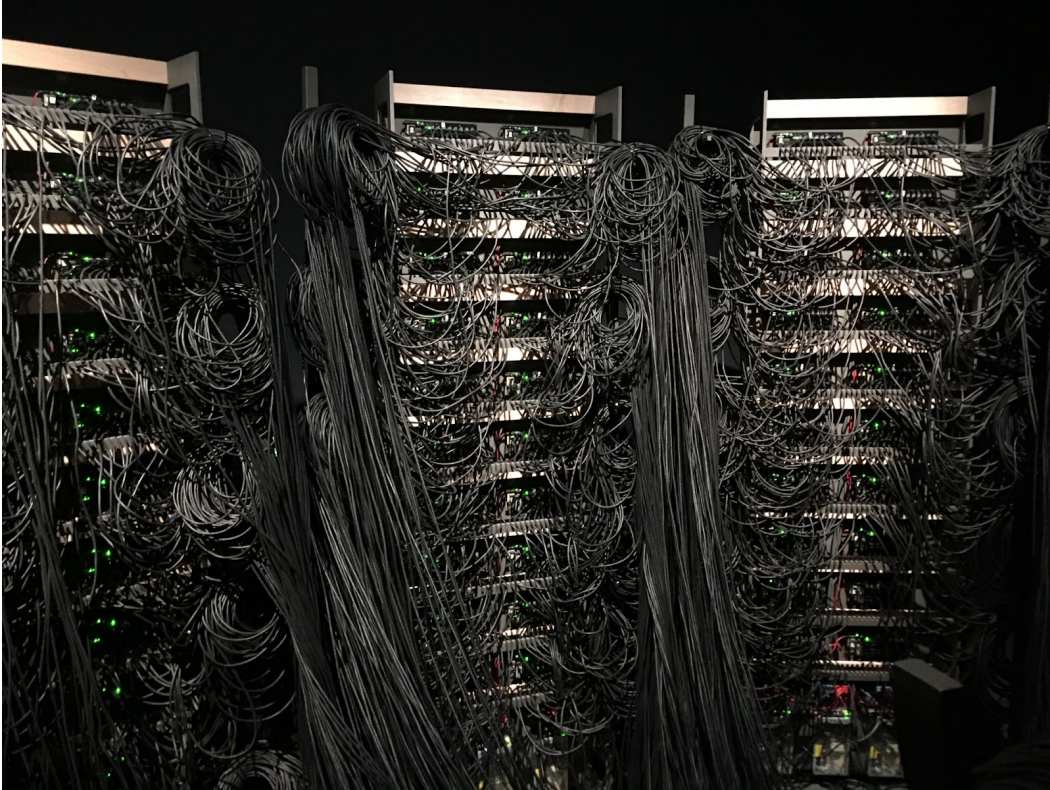

Patch Bay

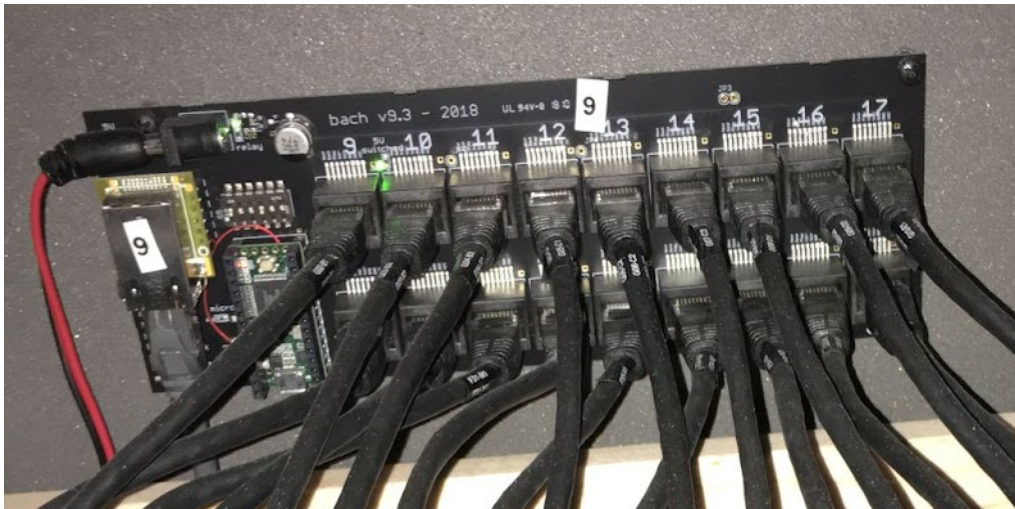

Controller Board

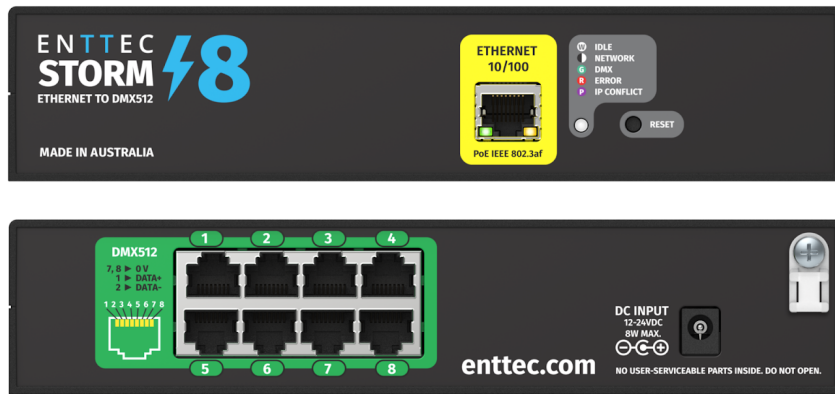

Enttec Storm8



Computer, Apple Mac Mini, i5, 2.1 Ghz, 4GB RAM



Logitech wireless RF keyboard

Wiring Diagrams and Connections

General connections of the patch bays with all the other components.

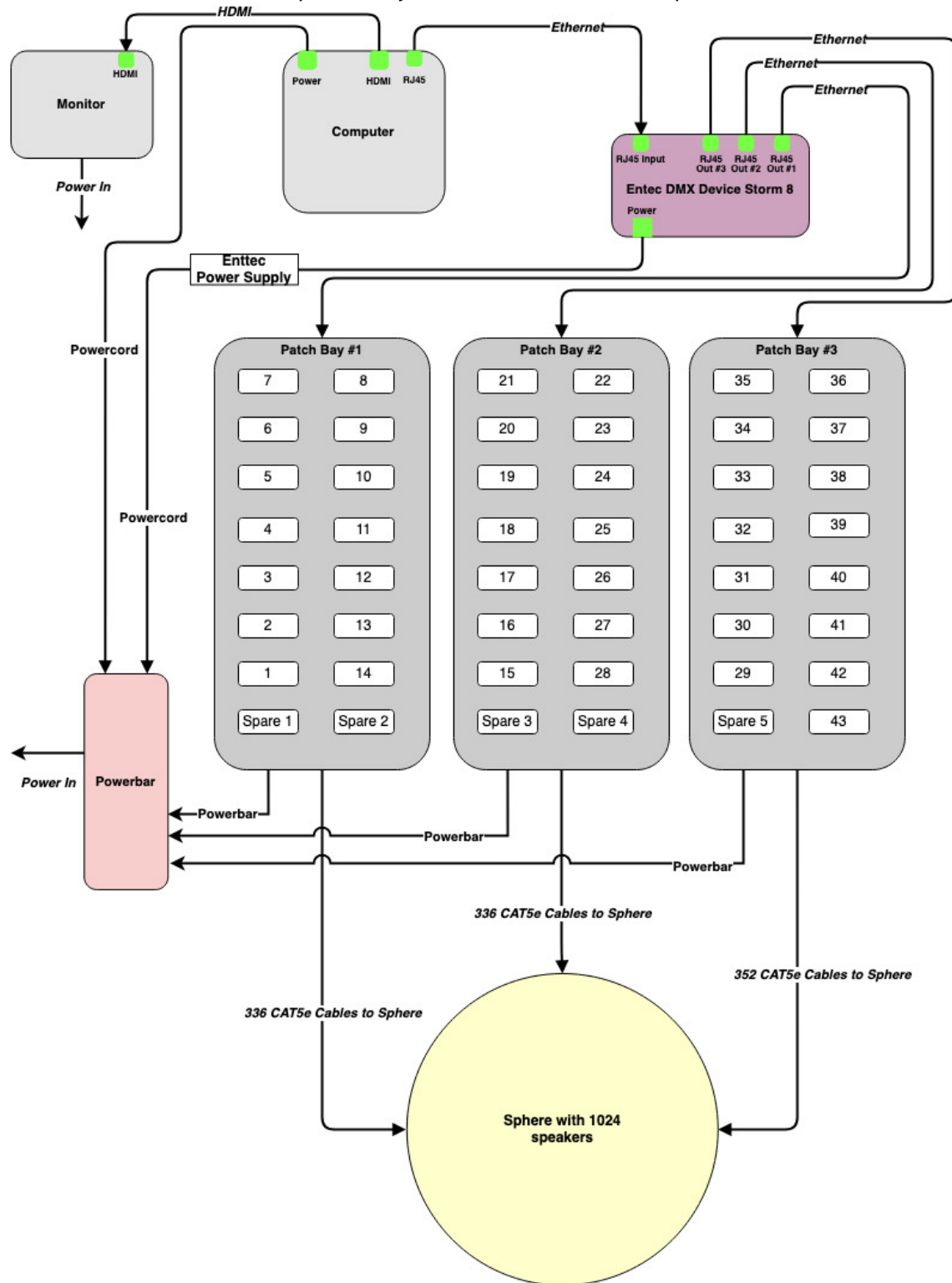

Connections Inside the patchbays. **** Note: number of spares per patchbay may vary. ****

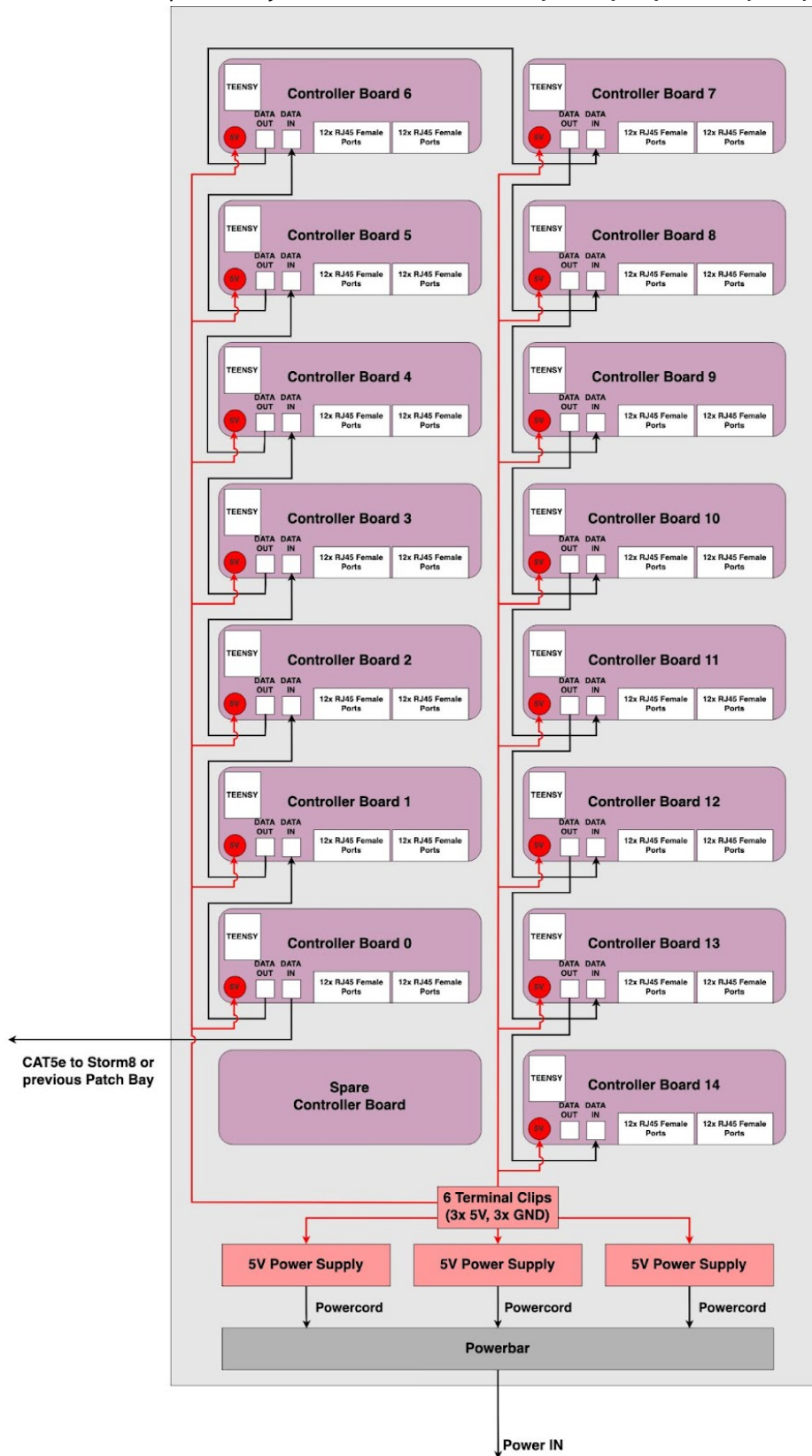

Single controller board connection

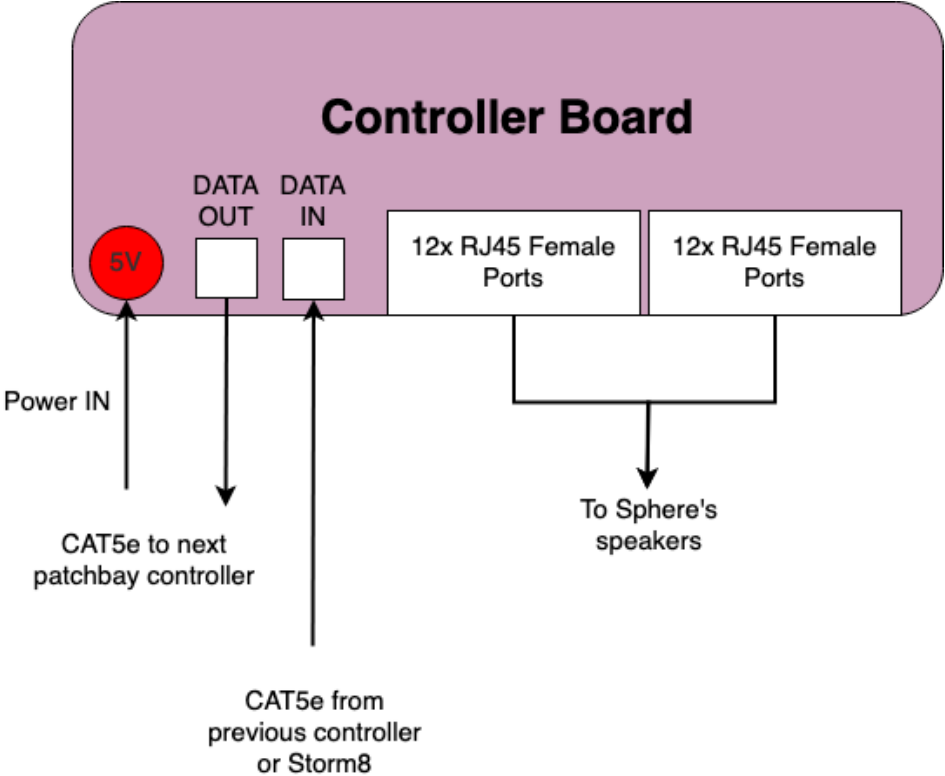

APPENDIX II - TECHNICAL DATA SHEETS

Metal Skeleton

The metal structure forming the sphere's skeleton is made out from aluminum plates - assembled with screws and union plates - and gives the sphere its vertical strength. The base of the sphere also presents some cover plates to finish the assembly. Metal spokes can be inserted in such a base to act as a stanchion within the sphere.

Wood Slats

The wood slats are used as shelves for the speakers and they also provide horizontal structural strength to the sphere. Made out of maple and coated with clear satin epoxy, they are installed while being leveled towards the center of the sphere so that speakers point towards a person standing in the sphere.

For every speaker in the sphere, there is a brass insert nested in a specific position into a wood slat. These brass inserts are for M4 x 0.70 thread size and 0.335" long (Spaenaur Barb-Sert 628-556).



Speaker Brackets

The speakers are held in place on the sphere while being screwed to a C-shaped metal bracket, which is then secured to a wood slat of the sphere with a screw screwed within a brass insert, positioned in the wood slat. Some brackets have an angle to hold the speaker further from the skeleton.



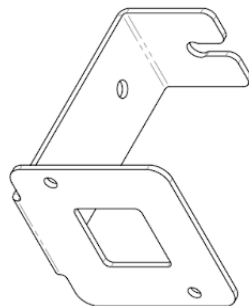
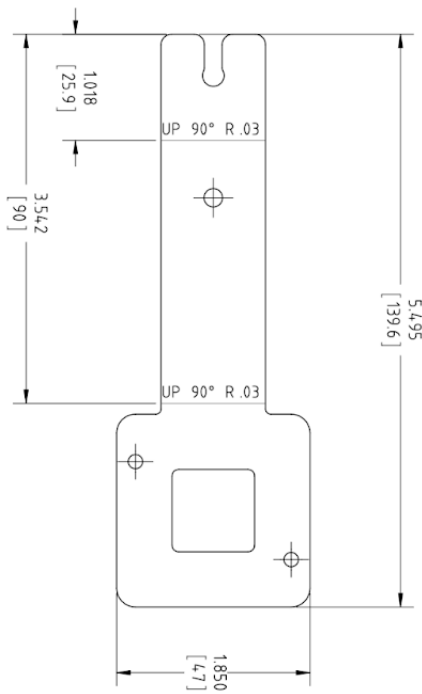
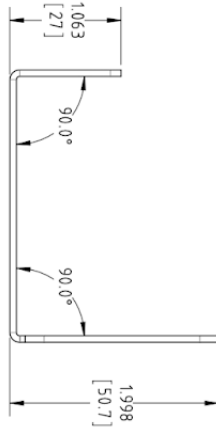
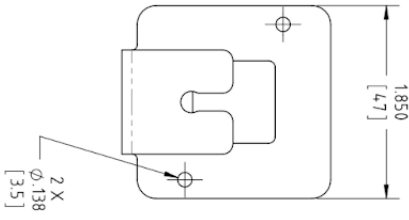
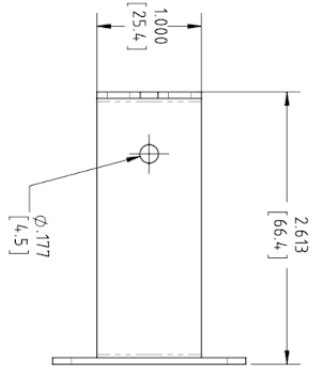

CLIENT
ANTIMODULAR

PROJECT NAME
BÄCK SPHERE
RE-EDITION SEPT. 2022

GENERICQUE
design

GENERICQUEDESIGN.COM

DESIGN DRAWING
P-244-101

ITEM NAME
SPEAKER BRACKET - STRAIGHT
DIMENSIONS

REVISION APPROVAL
R0

DATE
2022/10/11

DESIGNED BY
DRAWN BY
J.L.

PROCESS
LASER + PLAGIAGE

MATERIAL
5052-H32 1/16" EP.

QUANTITY
X 920

FUNCTION
-

SCALE
1:1

UNITS
MM

PAGES
1/4

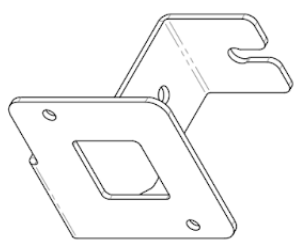
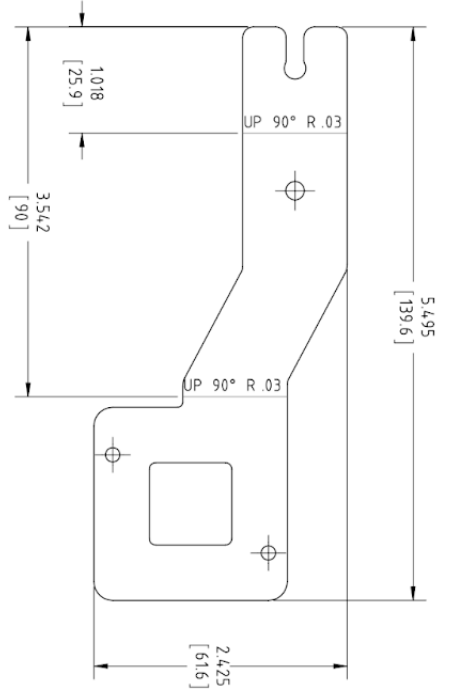
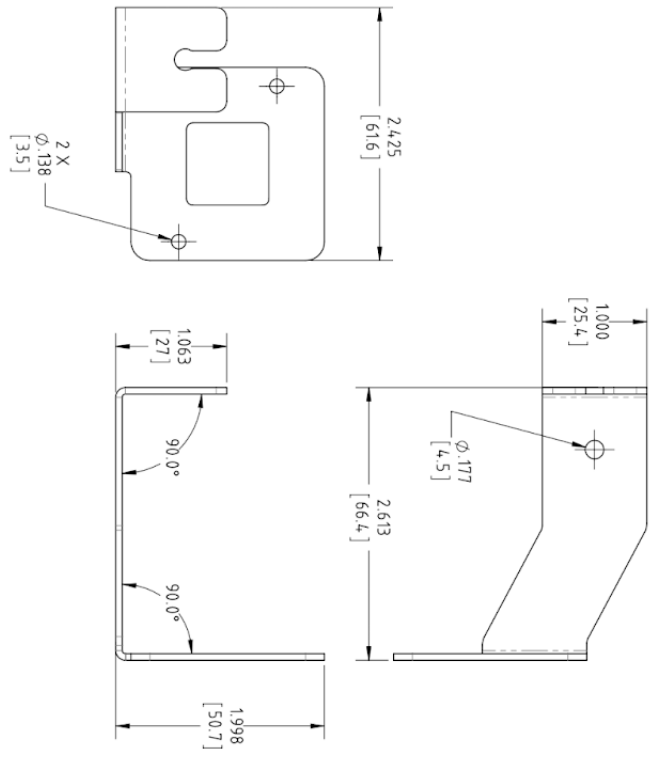

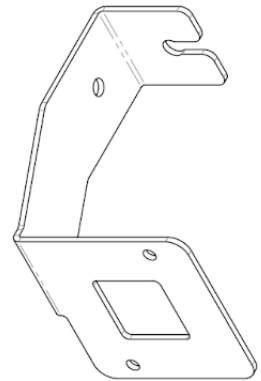
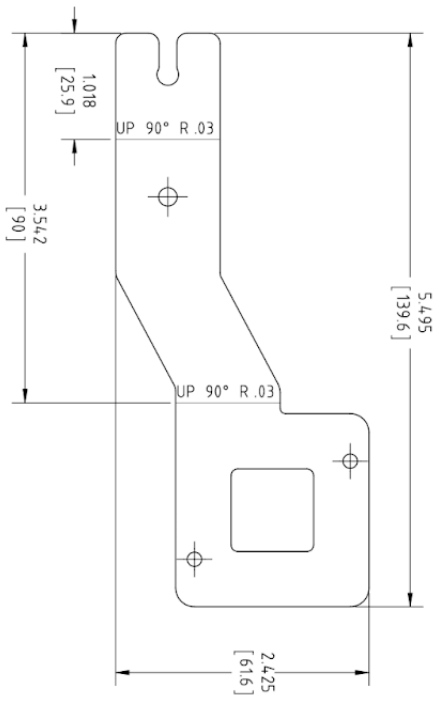
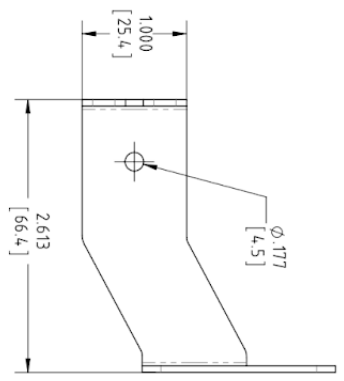
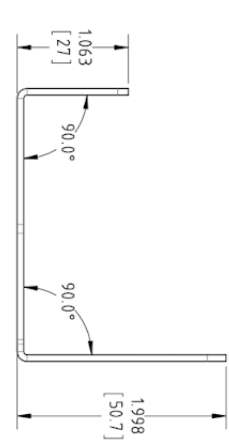
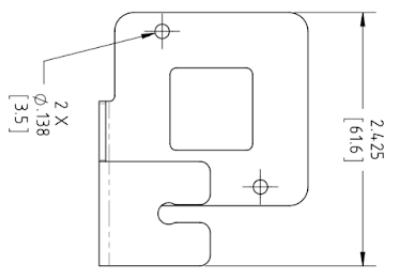

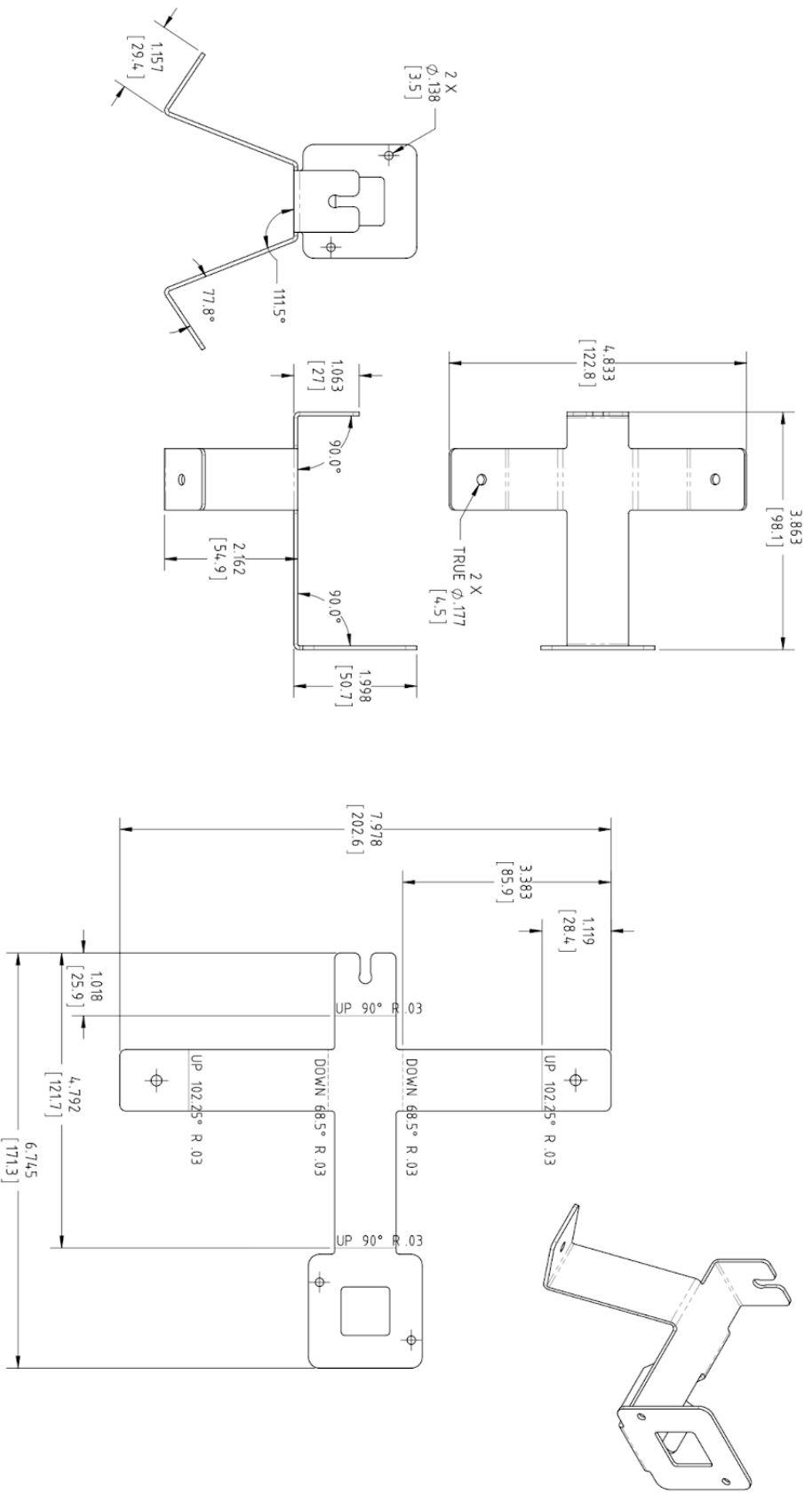

Speakers

The speakers have been custom built for the studio by Junjiahao Company Limited. The units used in this installation are Speakers version 3.

They receive 12V and DMX signals from the RJ45 connection and divert 5V to the 4 5 pin ports on the sides to control LEDs. They read a microSD card to play audio files and can control volume up, volume down, play, pause, next, back, and reset.

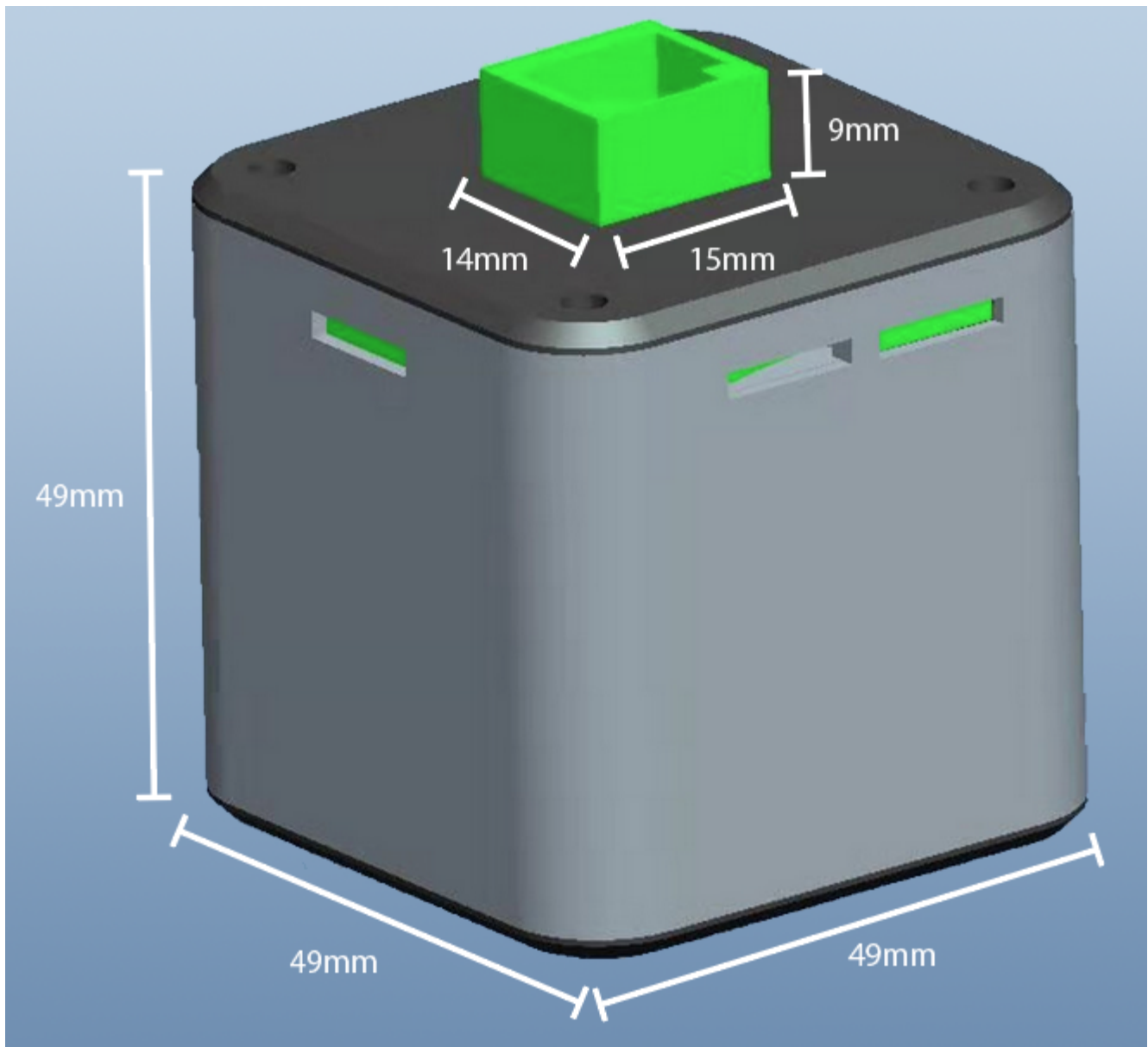

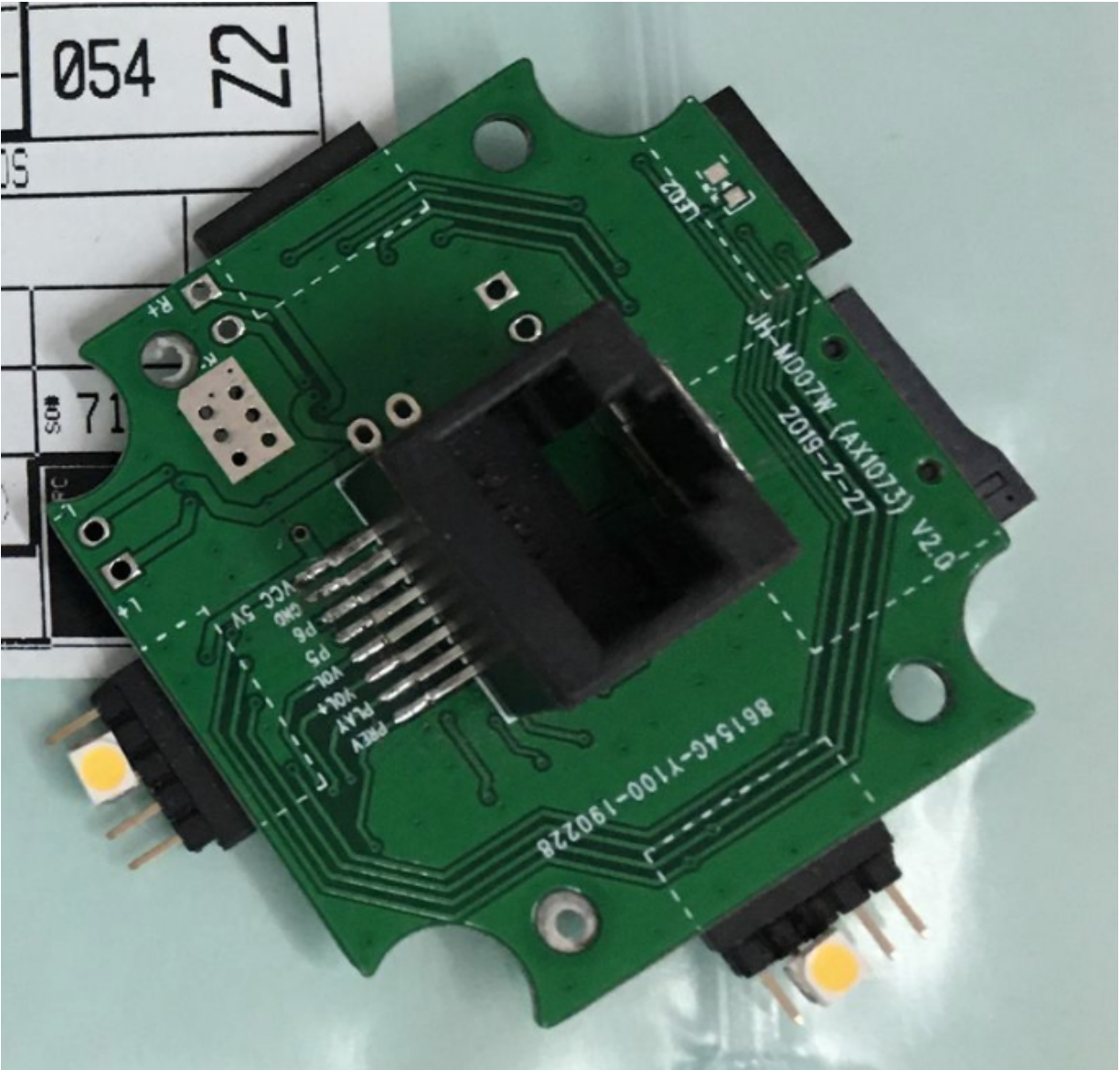

microSD Cards

Each speaker contains an SD card. The cards used are industrial grade SLC microSD cards: they better protect the files from getting corrupted. Each SD card contains a specific and unique composition of Johann Sebastian Bach (filename starting with 00-...) and 6 files that are common to each SD card.

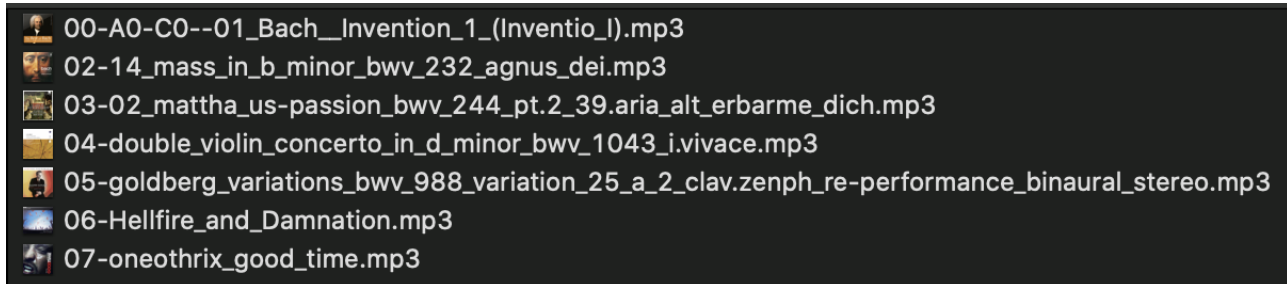

There is one microSD card for each Bach composition (1128 in total). Each speaker (total of 1024) hosts its own unique card and there are a total of 104 spare cards given with the artwork.

These microSD cards (256 MB to 1GB, SLC flash memory) need to be formatted in FAT16. While formatting with an OSX computer, ensure to keep the card's partition map schemes as Master Boot Record, not GUID or Apple Partition Map.

Ethernet Cables

For the assembly of the sphere, CAT5E ethernet cables have been used. The cables have a matte black jacket without any printing on them and they have clear connectors. The cable length for a speaker varies depending on its position in the sphere: possible lengths are 10 meters, 9 meters, 8 meters and 7 meters. Refer to the [Speakers: Position in Sphere, Label, Controller Connection and Cable Length](#) section to retrieve which informs which length is used with which speaker.

90 degrees Ethernet Couplers

In some cases, the speaker is located in a position that doesn't allow a connection with a regular cable - typically when located near a metal plate.



Patchbays (controller boards and power supplies)

The patchbays are hosting the controller boards, their power supplies.

Each patch bay has 3 power supplies feeding power to all controllers. A power supply outputs 5VDC, 40A, 200 W (part# LRS-200-5) and feed power to the controllers with red + black DC power cable Cable Assembly 2.1mm ID, 5.5mm OD, part# 10-01776.

The controllers PCB are custom designed in studio and are addressed with a Dip switch. A Teensy microcontroller is used in this design: with current board revision (Atmosphonia v4 - Mar 2019), the Teensy 4.0 is in use.



Top PCB view

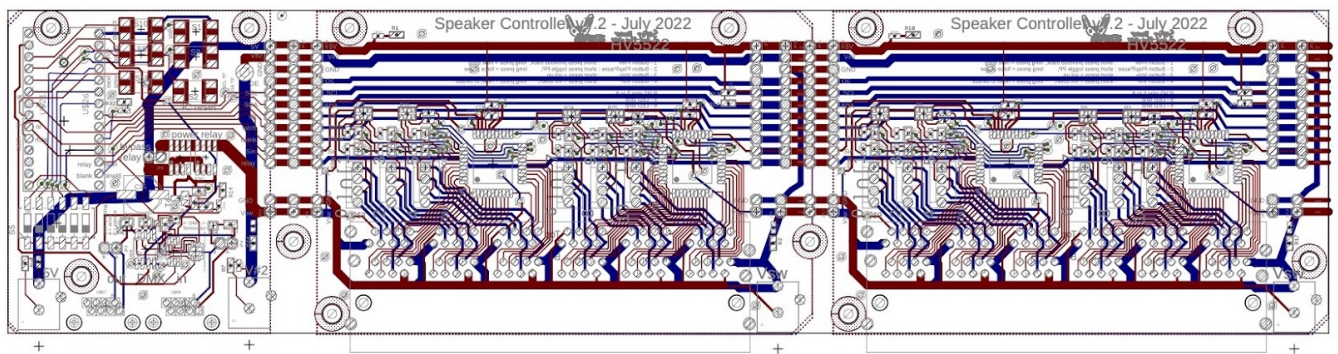

Board circuitry

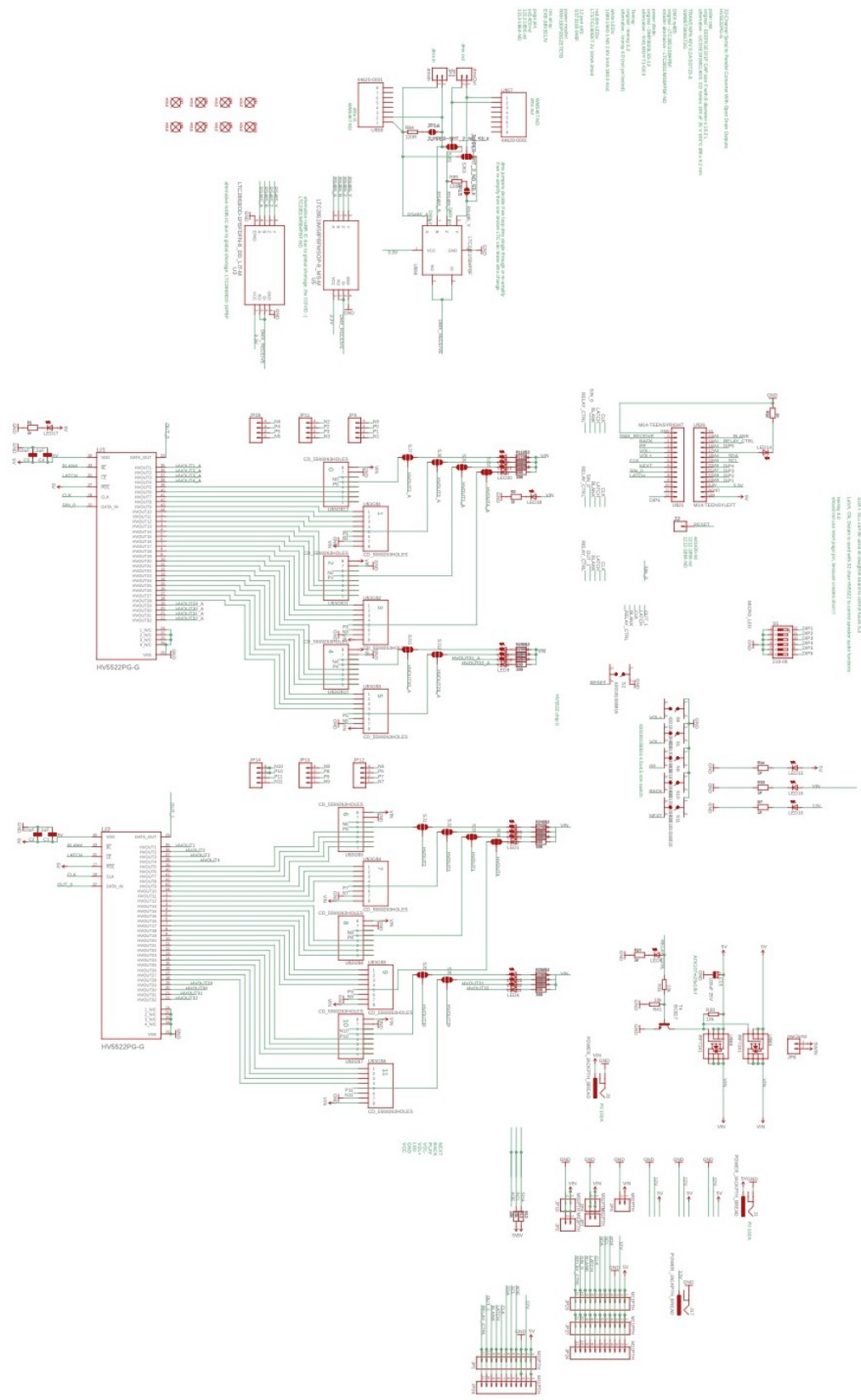

Schematics

The Dip switch value to apply according to the PCB ID should go as per following.

As DMX is a **serial signal with a special protocol**, it is possible to **apply a certain start address to every system** in the line.

This calculation tool shall **help you in finding the right dip-switch settings for a certain DMX address**. The dip switches are set according to binary calculation meaning that every dip switch can feedback only the values 0 and 1. The calculation is comparably simple: Every dip switch has the value 2^n where n is the number of the dip switch. First dip switch is 0 (computers start counting from 0, not from 1), so when it's switched on it says $2^0 = 1$. Dip switch 2 has the value 1 if switched on, so it is $2^1 = 2$. Third dip switch has $2^2 = 4$, fourth $2^3 = 8$.

To Set a value you first have to find the highest number that fits the value, then you add up smaller values.

Example:

DMX512 value 11 shall be set:

1. Highest number that fits is $2^3 = 8$
2. Second highest number is $2^1 = 2$
3. third highest number that fits is $2^0 = 1$

So setting would be: 11010000

Extracted from this website:

<https://www.laserworld.com/en/laserworld-toolbox/dmx-address-setting.html>

**** Precision: The physical controller ID (dip switch) value differs from the logical (software) controller ID referenced in the Speakers: Position in Sphere, Label, Controller Connection and Cable Length on the Controller Patching Information sections. ****

Every patchbay connects to a different Storm8 universe and has its own set of controller IDs. The first controller of a patchbay should have its Dip switch set to 0, the next controller would have its Dip switch set to 1, etc. On the next patchbay, the same logic should apply: the first controller will be set to ID 0 and so on.

Enttec Storm8



Storm 8 (70056)
Visit the ENTTEC website [for the latest version.](#)

Installation Safety Guidelines



- The device is convection cooled, ensure it receives sufficient airflow so heat can be dissipated.
- Do not cover the device with insulating material of any kind.
- Do not operate the device if the ambient temperature exceeds that stated in the device specifications.
- Do not cover or enclose the device without a suitable and proven method of dissipating heat.
- Do not install the device in damp or wet environments.
- Do not modify the device hardware in any way.
- Do not use the device if you see any signs of damage.
- Do not handle the device in an energized state.
- Do not crush or clamp the device during installation.
- Do not sign off a system without ensuring all cabling to the device and accessories has been appropriately restrained, secured and is not under tension.

Wiring diagrams

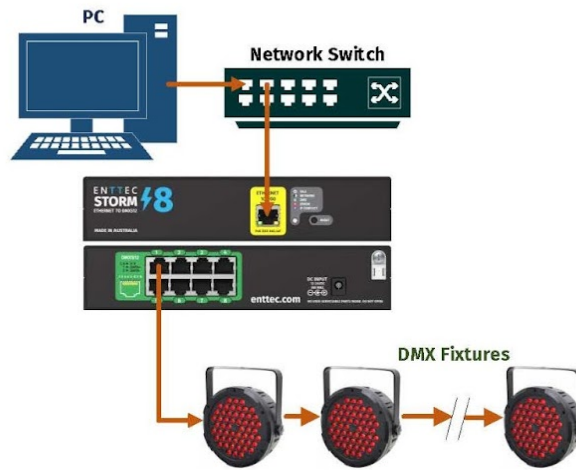

LED status indicator

The LED status indicator can be used to determine STORM8's current state. Each state is as follows:

LED Color	STORM8 Status
White (static)	Idle
Green	Sending DMX
Purple	IP conflict
Red	Device in boot / error

Out of the box

STORM8 will be set to a DHCP IP address as default. If the DHCP server is slow to respond, or your network does not have a DHCP server, STORM8 will fall back to the static IP address which will be 192.168.0.10 as default. By Default, all STORM8 ports are enabled with ArtNet selected. All port will output ArtNet universe number 0.

Networking

STORM8 can either be configured to be DHCP or Static IP address.

DHCP: On power up and with DHCP enabled, if STORM8 is on a network with a device/router with a DHCP server, STORM8 will request an IP address from the server. If the DHCP server is slow to respond, or your network does not have a DHCP server, STORM8 will fall back to the Static IP address. If a DHCP address is provided, this can be used to communicate with STORM8.

Static IP: By default (out of the box) the Static IP address will be 192.168.0.10. If STORM8 has DHCP disabled or if STORM8 falls back to the Static IP address after being unable to find a DHCP server, the Static IP address given to the device will become the IP address to communicate with STORM8. The fall-back address will change from the default once it's modified in the web interface.



Note: When configuring multiple STORM8's on a Static network; to avoid IP conflicts, ENTTEC recommends connecting one device at a time to the network and configuring an IP.

- If using DHCP as your IP addressing method, ENTTEC recommends the use of the sACN protocol, or Art-Net Broadcast. This will ensure that STORM8 continues to receive data if the DHCP server changes it's IP address.
- ENTTEC does not recommend unicasting data to a device with its IP address set through DHCP server on long term installations.

Web interface

Configuring STORM8 is done through a web interface which can be brought up on any modern web browser.

- Note: A Chromium based browser (i.e. Google Chrome) is recommended for accessing STORM8's web interface.
- Note: As STORM8 is hosting a web server on the local network and does not feature an SSL Certificate (used to secure online content), the web browser will display the 'Not secure' warning, this is to be expected.

Identified IP address: If you are aware of STORM8's IP address (either DHCP or Static), then the address can be typed directly into the web browsers URL field.

Unidentified IP address: If you are not aware of STORM8's IP address (either DHCP or Static) the following discovery methods can be used on a local network to discover devices:

- An IP scanning software application (i.e. Angry IP Scanner) can be run on the local network to return a list of active devices on a local network.
- Devices can be discovered using Art Poll (i.e. DMX Workshop if set to use ArtNet).
- The device Default IP address will be printed on the physical label on the rear of the product.
- ENTTEC free NMU (Node Management Utility) software for Windows and MacOS (support up to Mac OSX 10.11), which will Discover ENTTEC devices on the Local Area Network, displaying their IP addresses before opting to Configure the device, opening the Web Interface. Note: STORM8 is supported by NMU V1.96 and above.



Note: The eDMX protocols, the controller and the device using to configure STORM8 must be on the same Local Area Network (LAN) and be within the same IP address range as STORM8. For example, if your STORM8 is on Static IP address 192.168.0.10 (Default), then your computer should be set to something such as 192.168.0.20. It is also recommended that all devices Subnet Mask are the same across your network.

Top menu

The top menu allows all STORM8 web pages to be accessed. Menu option is highlighted blue to indicate which page the user is on.

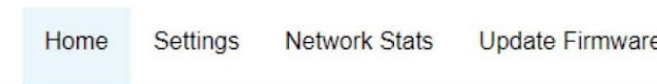

Home

Home tab displays the following information:

- Device (Node) Name.
- Firmware version on device.
- DHCP status – (either enabled / disabled).
- IP address.
- Netmask.
- Gateway.
- Mac Address.
- Link Speed.
- Input protocol set on device.
- Output ports status
 - Universe
 - Click on universe underlined in blue to inspect DMX value per channel)
 - Merge status
 - ErrorD: Merge is disabled but detected multiple data source from more than 2 IP address.
 - ErrorE: Multiple data source from more than 2 IP address detected.

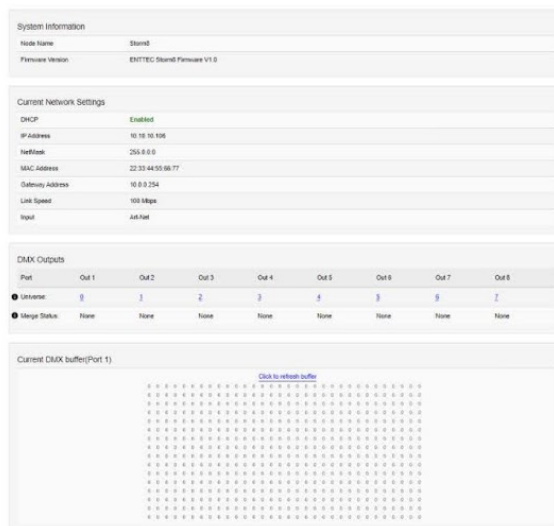

Settings

Settings tab displays the following information:

- Change a device (Node) name for identification.
- Enable/disable DHCP.
- Specify static network settings.
- Set the input protocol (Art-Net, sACN)
- Set DMX outputs ports settings
 - Enable/Disable port
 - Universe
 - Refresh rate
 - Merging option
 - None (Merging is disabled, support 1 source only)
 - HTP (Highest takes precedence, 2 sources)
 - LTP (Latest takes precedence, 2 sources)
- Reset to factory defaults.
- Reboot the device.

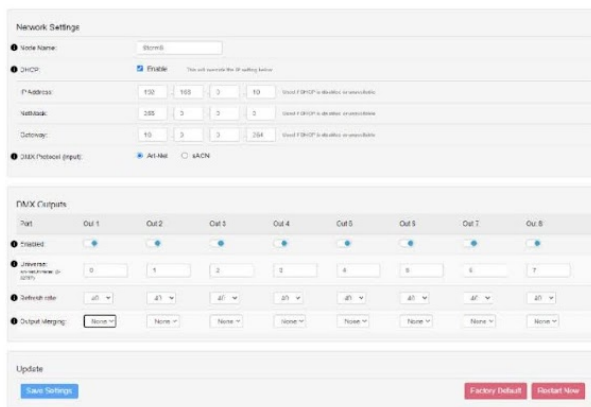

Network stats

The Network page shows statistics for the DMX protocol enabled.

Art-Net

The information provided is:

- Poll packets received.
- Last IP poll packets were received from.
- Last port data received from.
- DMX Data Packets Received
- DMX Data Packets Sent

Summary	
Poll Packets Received	0
Last IP	0.0.0.0
Last Port	0

Art-Net DMX	
DMX Data Packets Received	0
DMX Data Packets Sent	0

sACN

The information provided is:

- Data packets received
- Data packets sent
- Last IP
- Last port

Summary	
Data Packets Received	0
Data Packets Sent	0
Last IP	0.0.0.0
Last Port	0

Update firmware

It is strongly recommended that STORM8 is updated with the latest firmware, available on the ENTTEC website. This firmware can be loaded to the driver through its web interface by carrying out the following steps:

1. Browse and select the correct firmware version on your PC.

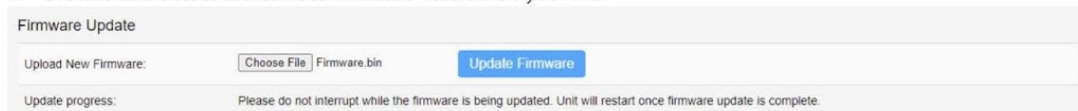

2. Press the Update Firmware button.
3. Once the firmware update is complete, the device will reboot.

Reset to factory defaults

Factory resetting the product results in the following:

- Resets device name
- Enables DHCP
- Static IP address reset (IP address = 192.168.0.10)
- Resets the gateway IP.
- Netmask is set to 255.0.0.0
- Input protocol is set to Art-Net.
- All ports set as "Enabled"
- Universe for Port1 = 0, Port2 = 1, Port3 = 2, Port4 = 3, Port5 = 4, Port6 = 5, Port7 = 6, Port8 = 7.
- All ports refresh rate as "40"
- All ports output merging as "None"

Using web interface

The reset to defaults command can be found under the Settings tab.

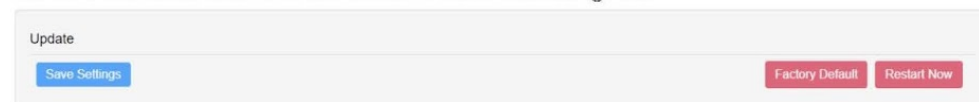

Once the command is pressed, a pop-up would appear as shown in the image below:



Using the reset button

The reset button restores the network configuration of STORM8 to factory defaults:

- To reset to factory defaults, the following procedure must be performed:
- Power off the unit
- Press and hold the Reset button.
- While holding the Reset button, power up the unit, and keep holding the button for 3 seconds.
- Release the Reset button once the status led starts blinking red.
- Power cycle the unit

Tips and guidelines

I'm unable to connect to web interface:

Ensure that ENTTEC product and your computer are on the same subnet

To troubleshoot:

1. Connect product directly to your computer using a Cat5 cable and power it on.
2. Give your computer a Static IP address (e.g.: 192.168.0.10)
3. Change computer Netmask to (255.0.0.0)
4. Open NMU and select the network adaptor connected to product.
5. If you have multiple networks (WiFi etc.), please try to disable all other networks except the one ENTTEC product is connected to.
6. Once NMU finds the product, you will be able to open the device webpage and configure it.
7. Factory Reset the device using the button if following the steps above and navigate to product default IP if this did not resolve the issue.

Servicing, Inspection & Maintenance



- The device has no user serviceable parts. If your installation has become damaged, parts should be replaced.
- Power down the device and ensure a method is in place to stop the system from becoming energized during servicing, inspection & maintenance.

Key areas to examine during inspection:

- Ensure all connectors are mated securely and show no sign of damage or corrosion.
- Ensure all cabling has not obtained physical damage or been crushed.
- Check for dust or dirt build up on the device and schedule cleaning if necessary.
- Dirt or dust buildup can limit the ability for a device to dissipate heat and can lead to damage.

To order replacement devices or accessories contact your reseller or message ENTTEC directly.

Cleaning

Dust and dirt build up can limit the ability for the device to dissipate heat resulting in damage. It's important that the device is cleaned in a schedule fit for the environment it is installed within to ensure maximum product longevity.

Cleaning schedules will vary greatly depending on the operating environment. Generally, the more extreme the environment, the shorter the interval between cleanings.



- Before cleaning, power down your system and ensure a method is in place to stop the system from becoming energized until cleaning is complete.
- Do not use abrasive, corrosive, or solvent-based cleaning products on a device.
- Do not spray device or accessories. The device is an IP20 product.

To clean an ENTTEC device, use low-pressure compressed air to remove dust, dirt and loose particles. If deemed necessary, wipe the device with a damp microfiber cloth.

A selection of environmental factors that may increase the need for frequent cleaning include:

- Use of stage fog, smoke or atmospheric devices.
- High airflow rates (i.e., in close proximity to air conditioning vents).
- High pollution levels or cigarette smoke.
- Airborne dust (from building work, the natural environment or pyrotechnic effects).

If any of these factors are present, inspect all elements of the system soon after installation to see whether cleaning is necessary, then check again at frequent intervals. This procedure will allow you to determine a reliable cleaning schedule for your installation.

Package content

- STORM8 (70056)
- 2m cat5 cable (79102)
- 1 X 12V PSU adaptor with international plugs
- Rack mounting bracket (79161) x2pcs + Screws x6pcs
- Surface/Din mounting bracket (79162) x 2pcs + Screws x4pcs
- Din Clip x2pcs + Screws x4pcs
- ReadMe Card

Ordering information

For further support and browse ENTTEC'S range of products, visit the ENTTEC website

Item	SKU
STORM8	70056

enttec.com

MELBOURNE AUS / LONDON UK / RALEIGH-DURHAM USA

Due to constant innovation, information within this document is subject to change.

Computer and Software

At the time of writing this manual, the software operating on the computer is coded under openFrameworks' platform. Software version referred to in this manual is #85 20230519 and runs on an Apple computer on OSX 12.2. Such software was initially released and tested on a 2020 Apple MacMini with an M1 3.2GHz processor, 8GB of RAM and 256 GB of SSD.

The software bachSphere.app is launched by the custom-made software delayOpen.app that, as the name implies, delays the software launch to allow all system resources to be loaded in priority.

APPENDIX III - PLAN VIEWS: SPHERE AND COMPONENTS

General Dimensions

generique
design

CLIENT
ANTIMODULAR

DESIGN DRAWING
AG-244-1000.1

PROJET / PROJECT
SPHERE PACKING - BACH
RE-EDITION SEPT. 2022

TITRE / TITLE
ASSEMBLAGE GÉNÉRAL
GENERAL DIMENSIONS

REVISION APPROUVÉ / APPROVED
R0

DATE / DATE
2022/12/14

DESIGNER / DESIGNER
J.L.

PROCESSE / PROCESS
MATERIAL / MATERIAL
QUANTITE / QUANTITY
REVISIONS / REVISIONS

ESCALE / SCALE
1:32

UNITÉ / UNIT
POUSSES / INCHES
PAGE / PAGE
1/2

CE DESSIN EST STRICTEMENT CONFIDENTIEL ET NE DOIT PAS ÊTRE REPRODUIT OU UTILISÉ SANS LE CONSENTEMENT ÉCRIT DE GÉNÉRIQUE DESIGN INC. THIS DRAWING IS STRICTLY CONFIDENTIAL AND MUST NOT BE REPRODUCED OR USED WITHOUT THE WRITTEN CONSENT OF GÉNÉRIQUE DESIGN INC.

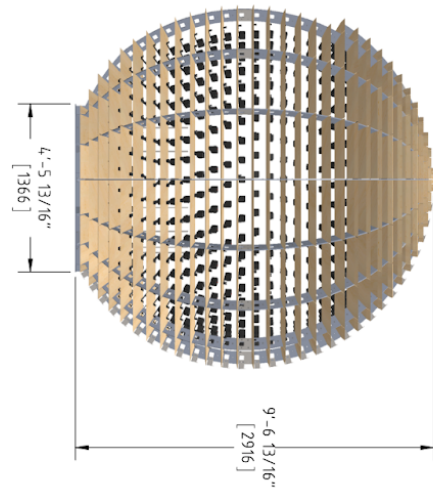
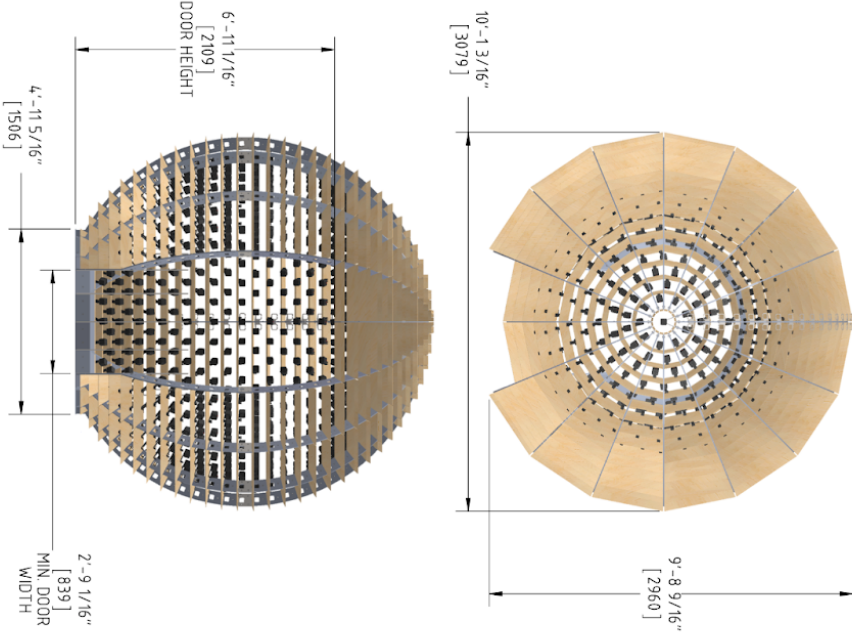

Nomenclature of the Sphere Sections

Sphere Packing: Bach
Series 301
Level 1
Nomenclature of shelves

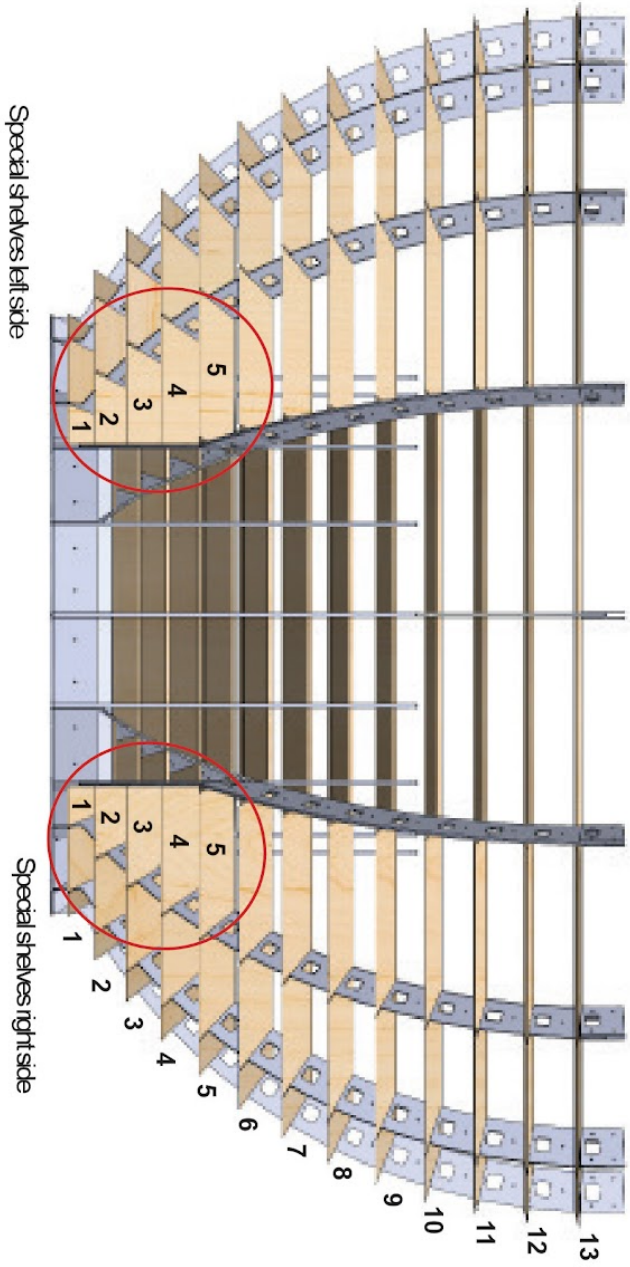

Orientation of the shelf's angle as so:

Bach sphere
Series 302
Level 2
Nomenclature of shelves

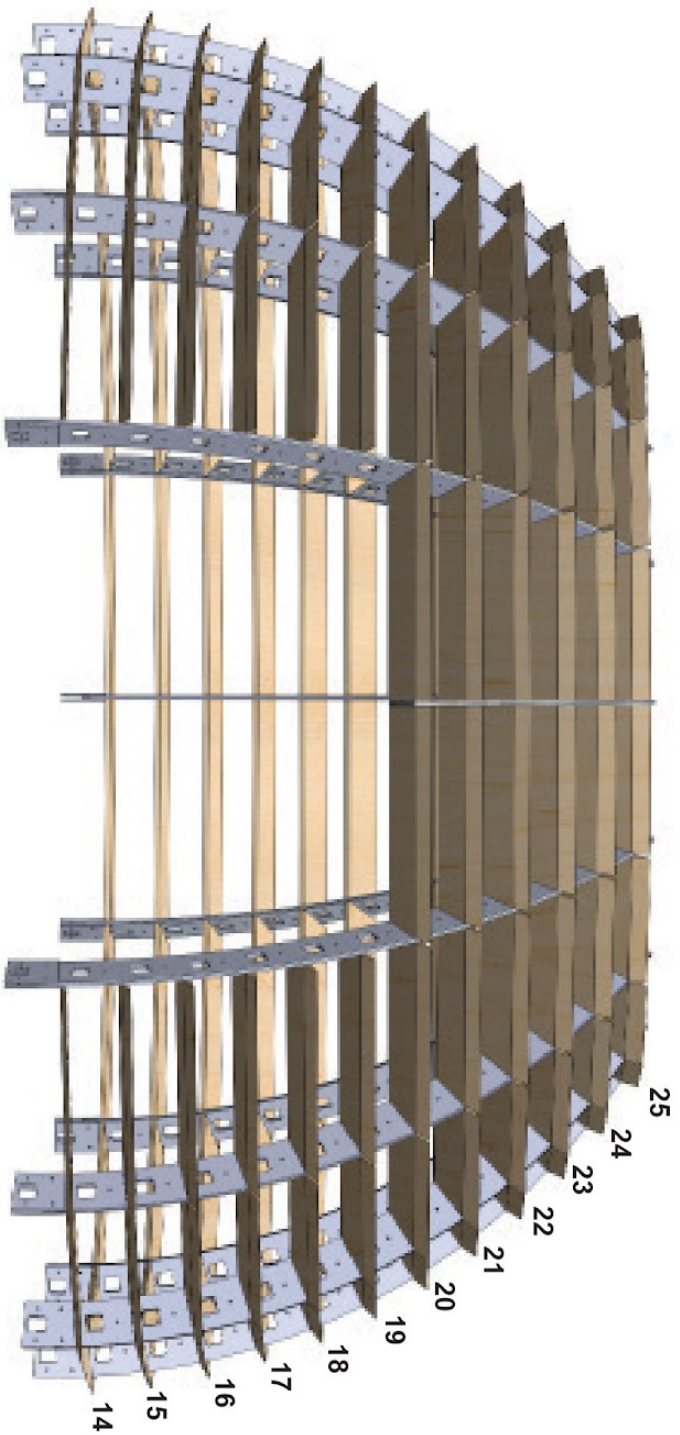

Orientation of the shelf's angle as so:



Bach sphere
Série 303
Level 3
Nomenclature of shelves

Dome

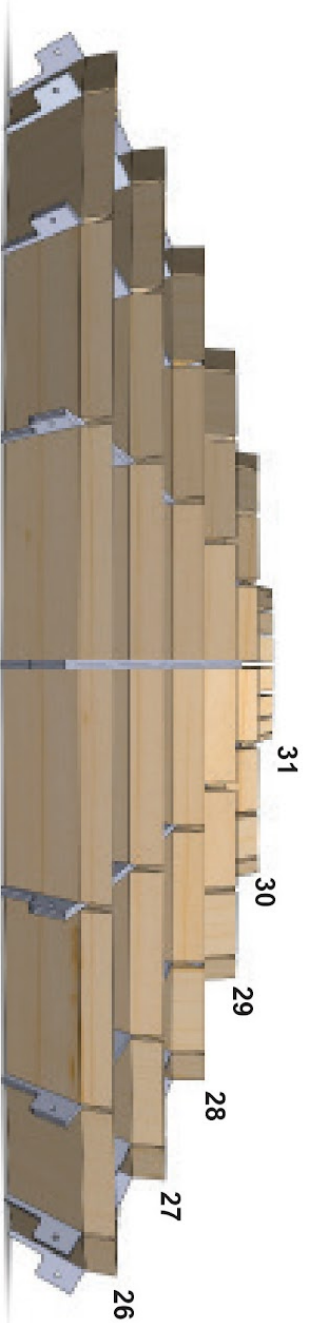

Orientation of the shelf's angle as so:



Bach sphere
Series 301

Level 1
Nomenclature of segments

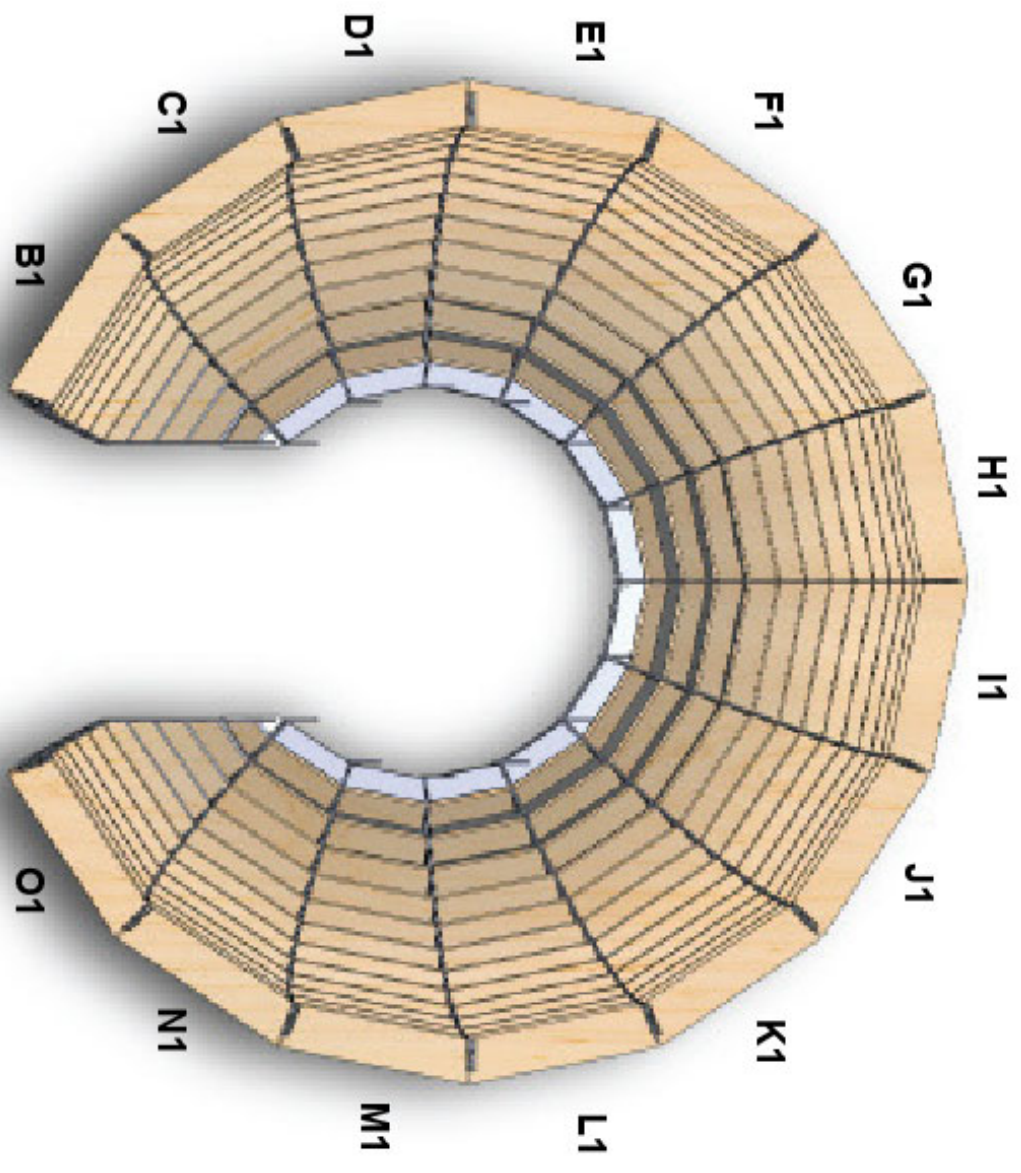

Bach sphere
Series 302
Level 2
Nomenclature of segments

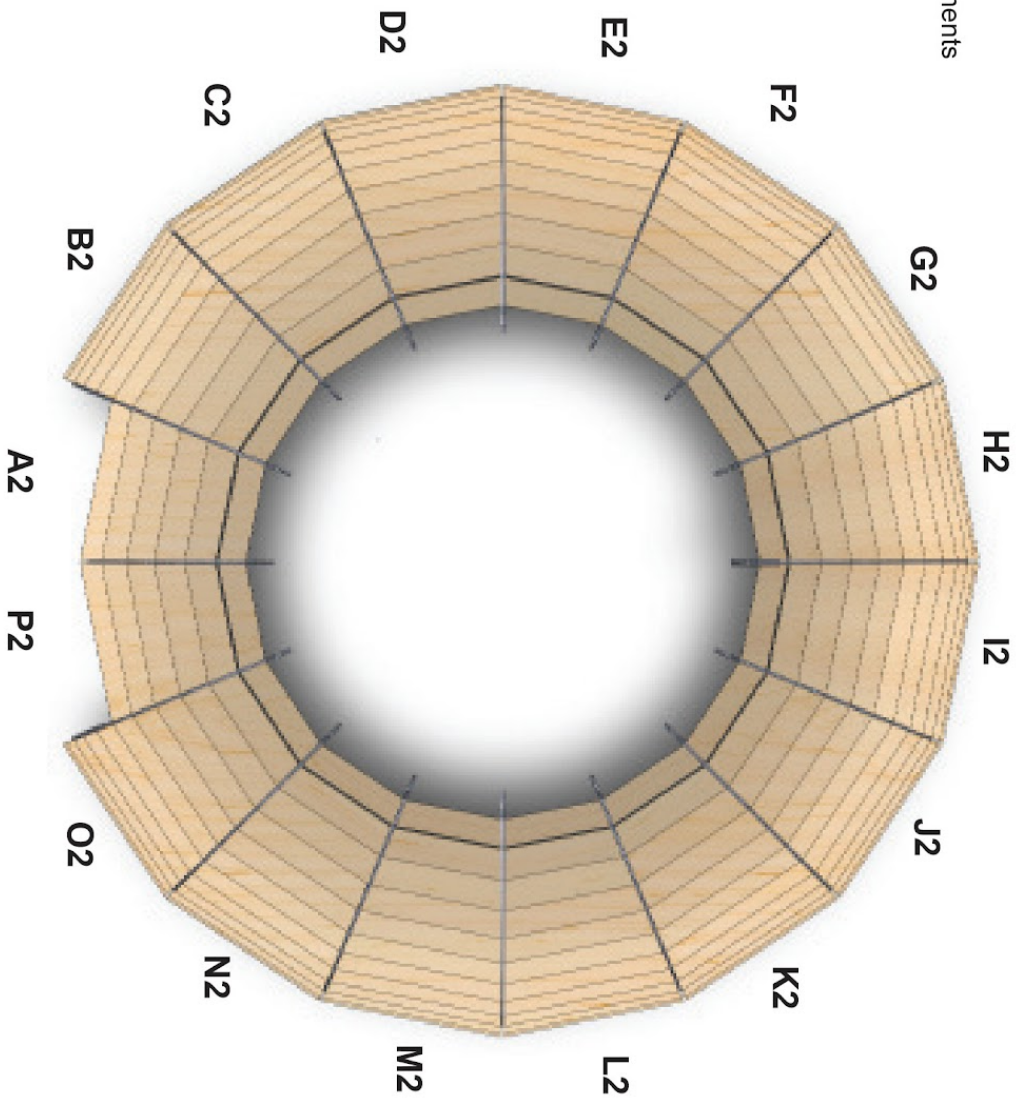

**Bach sphere
Series 303**

Level 3

Nomenclature of segments

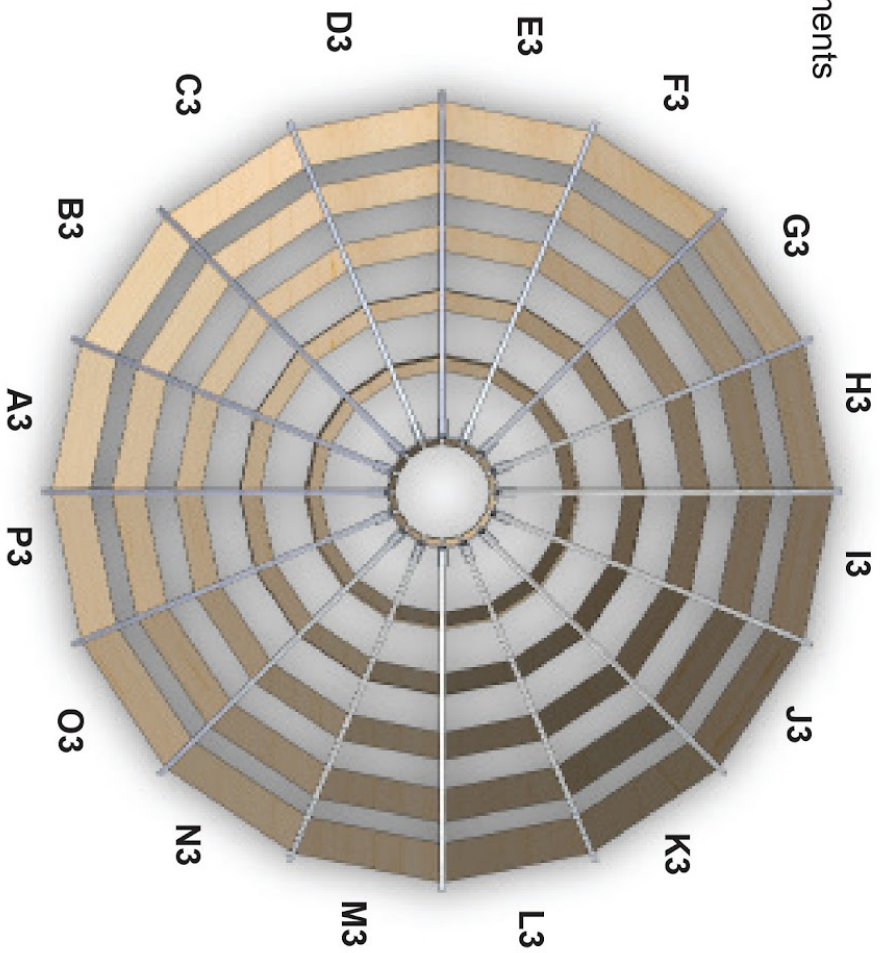

Dome

Sphere Eighths and Dome

While the sphere has been built from plenty of wood slats and metal spines, it has been built to be easily disassembled into 9 parts, the dome (also called top part or top hat - row Z to EE) and the "eighths": lower left side back, lower left side front, lower right side back, lower right side front, top left side back, top left side front, top right side back, top right side front.

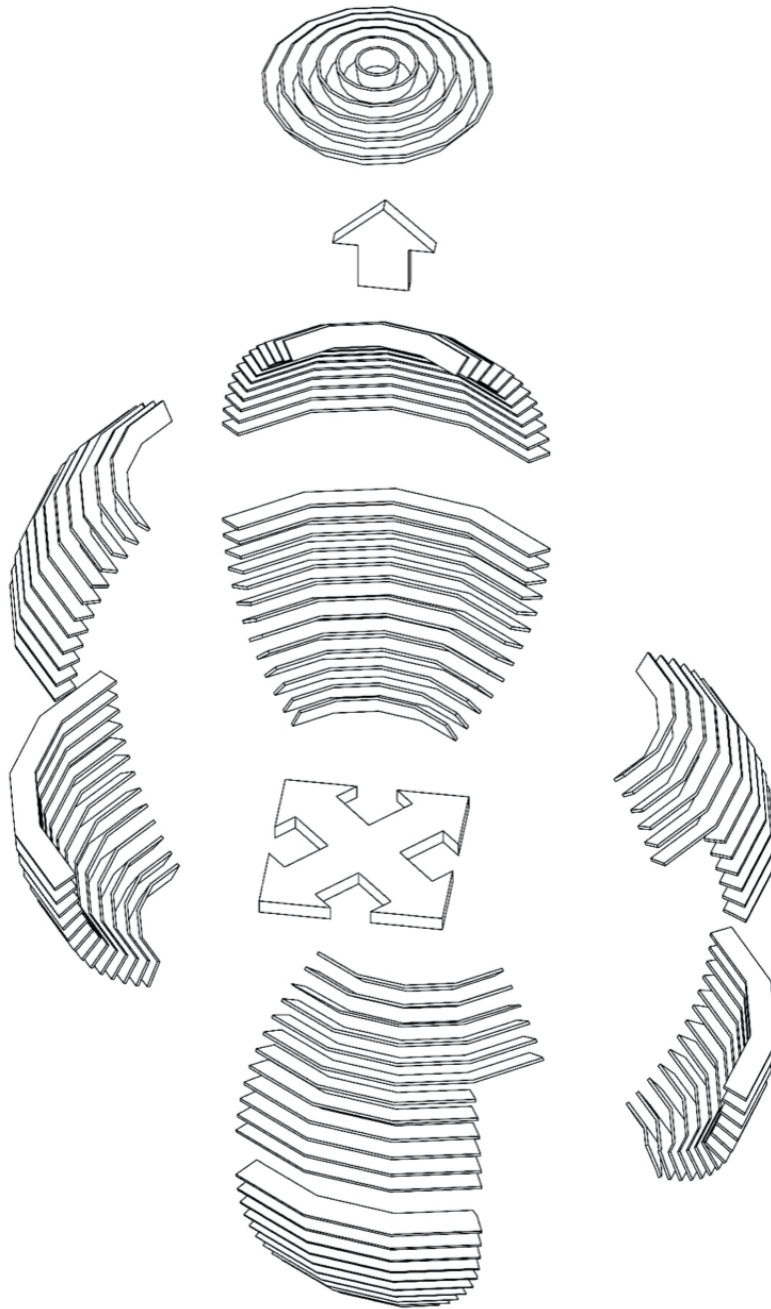

LOWER LEFT SIDE BACK (SERVER RACK)

TOP VIEW

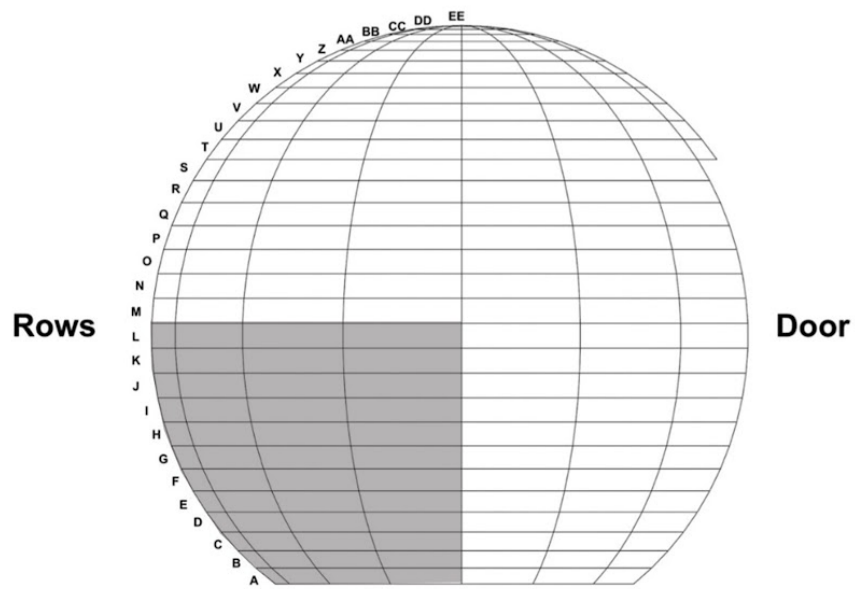
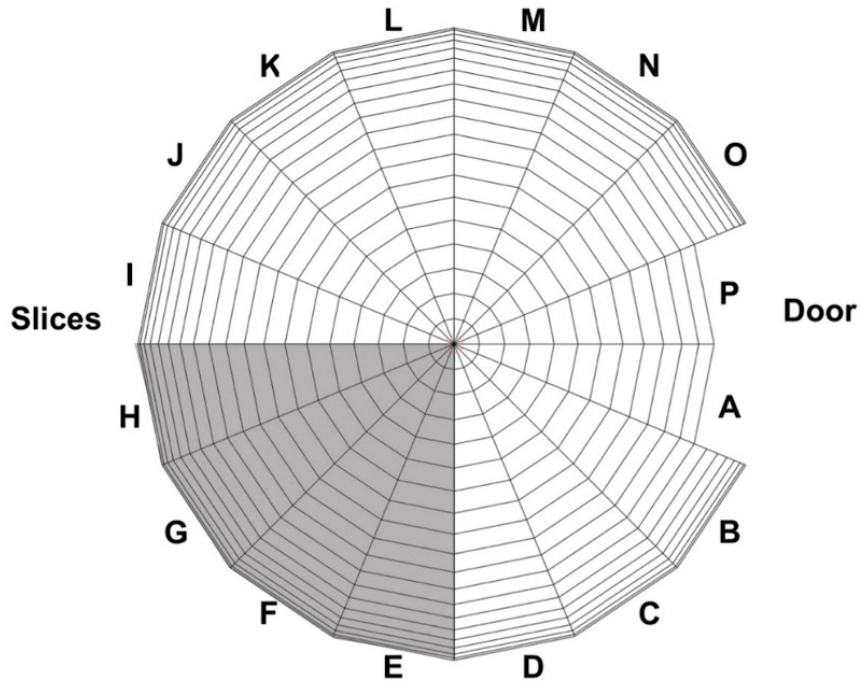

Floor SIDE VIEW

LOWER LEFT SIDE FRONT (DOOR)

TOP VIEW

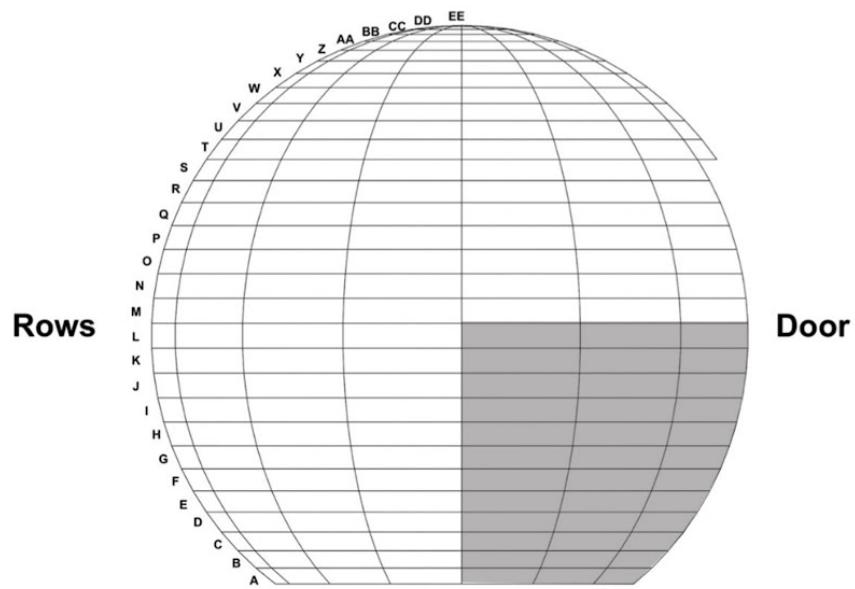
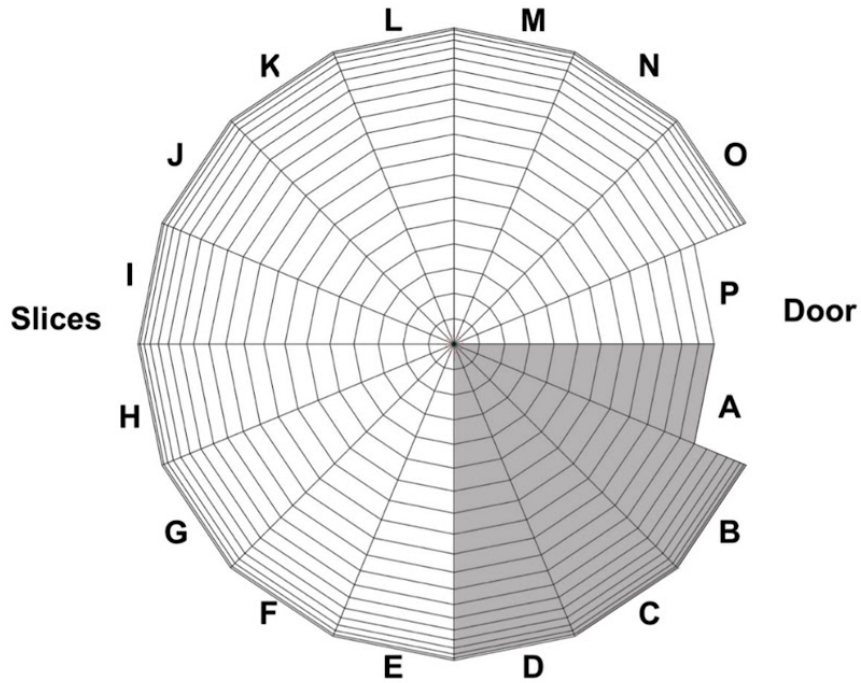

Floor SIDE VIEW

LOWER RIGHT SIDE BACK (SERVER RACK)

TOP VIEW

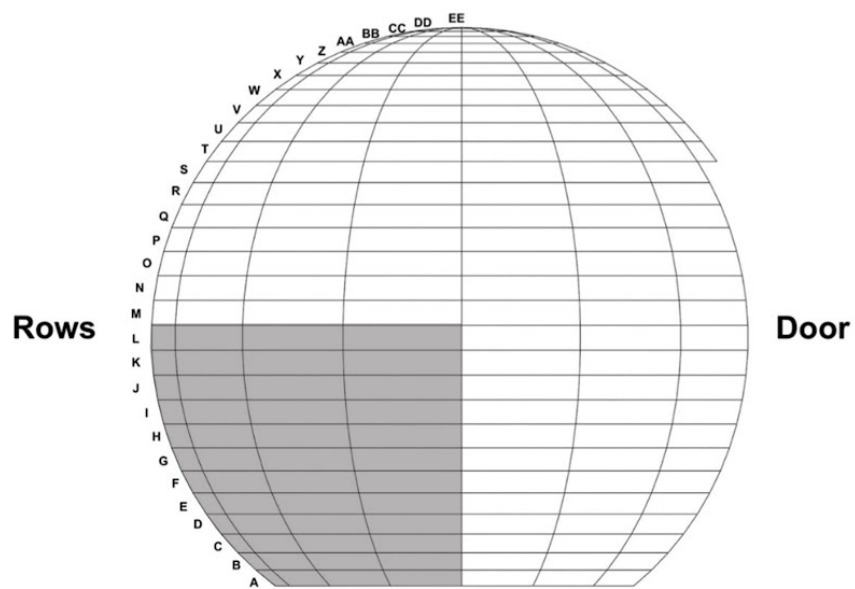
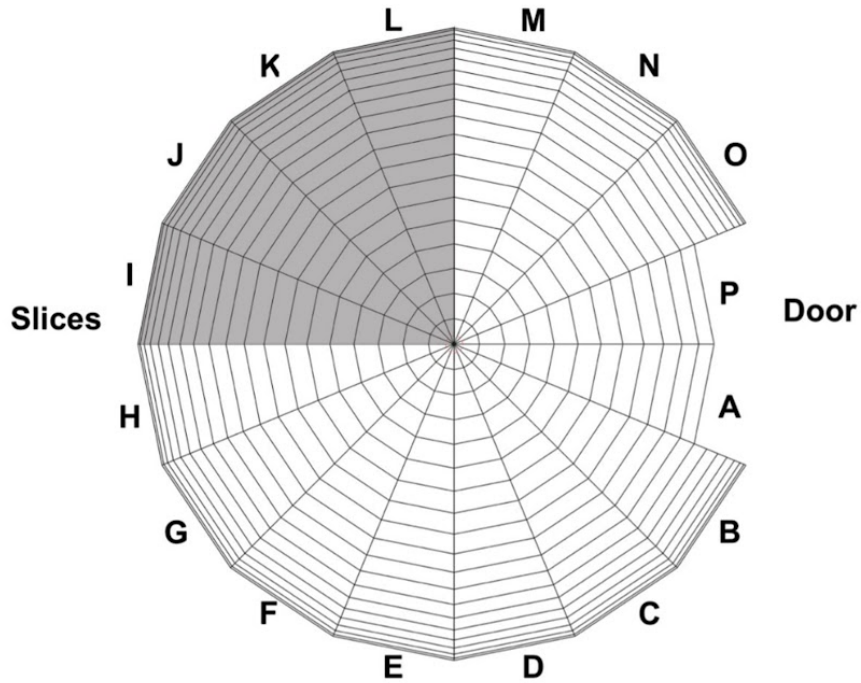

Floor SIDE VIEW

LOWER RIGHT SIDE FRONT (DOOR)

TOP VIEW

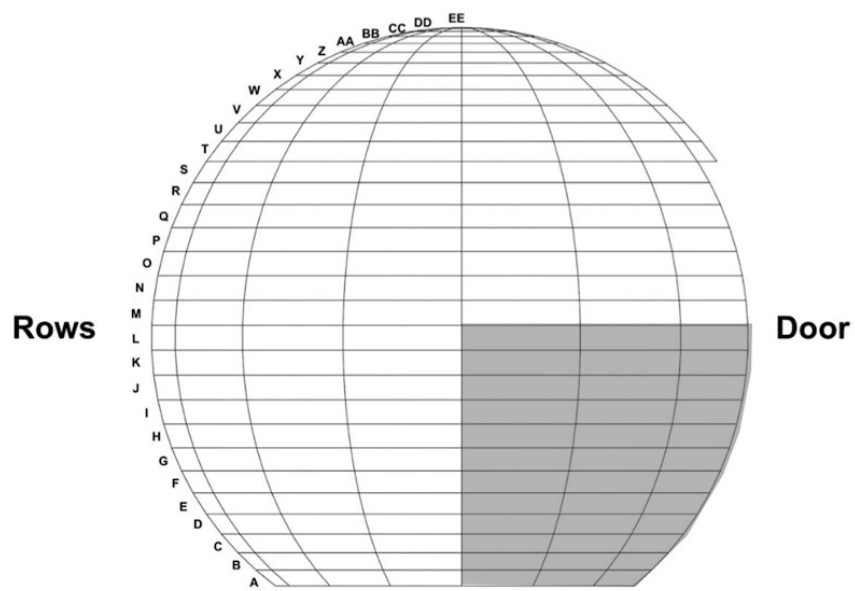
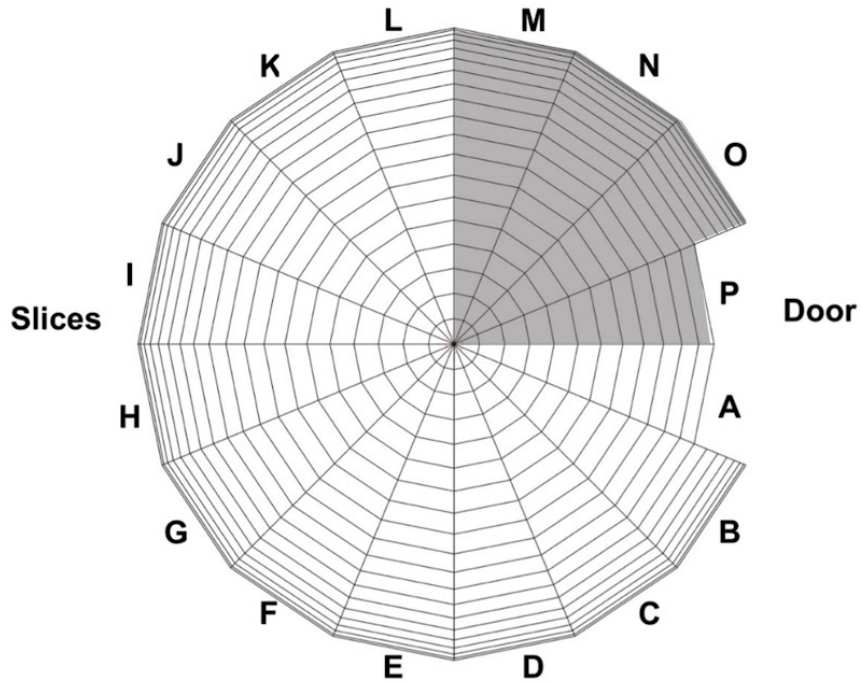

Floor SIDE VIEW

UPPER LEFT SIDE BACK (SERVER RACK)

TOP VIEW

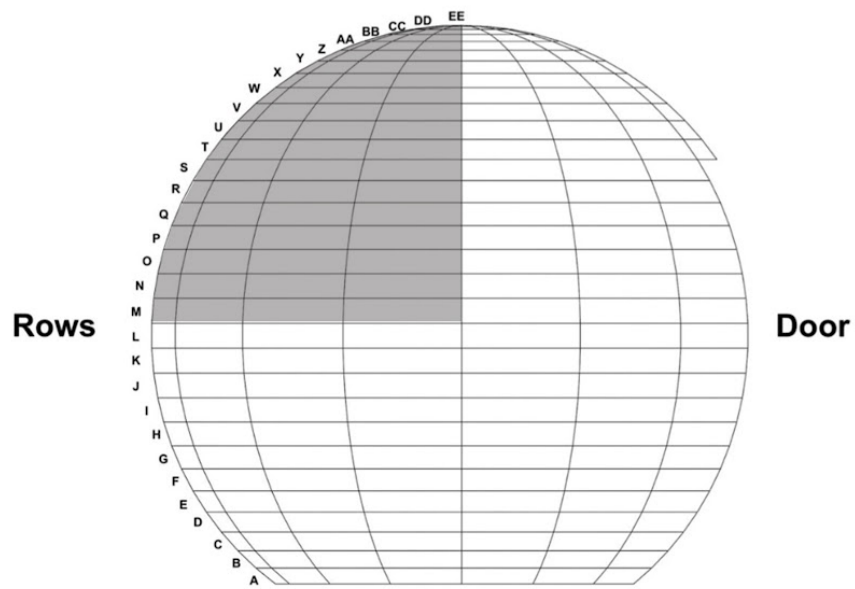
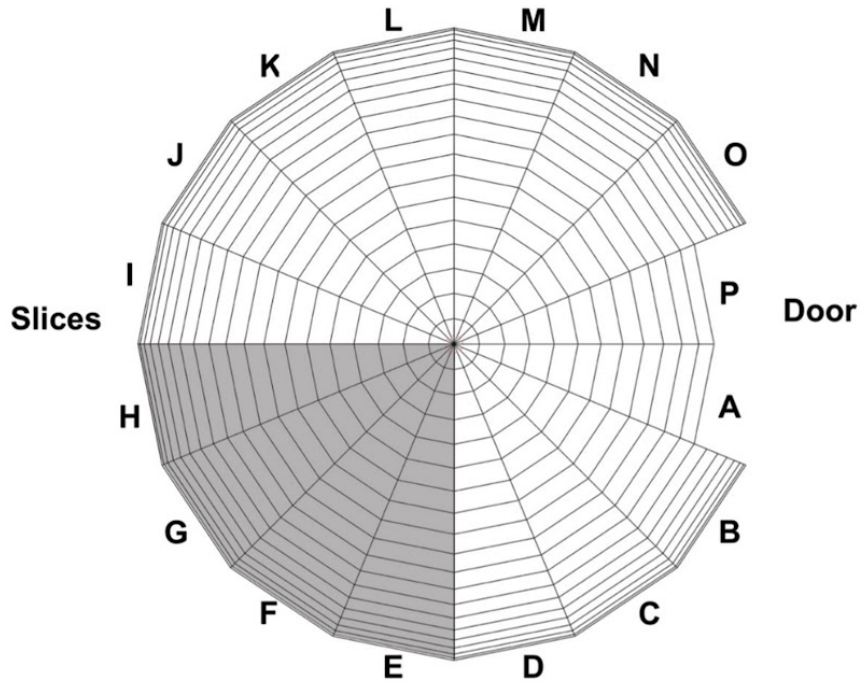

Floor SIDE VIEW

UPPER LEFT SIDE FRONT (DOOR)

TOP VIEW

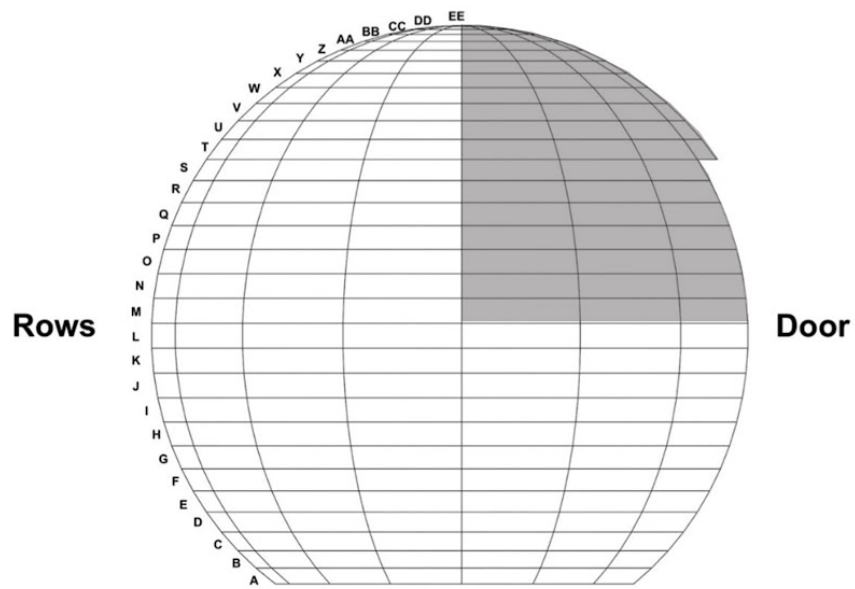
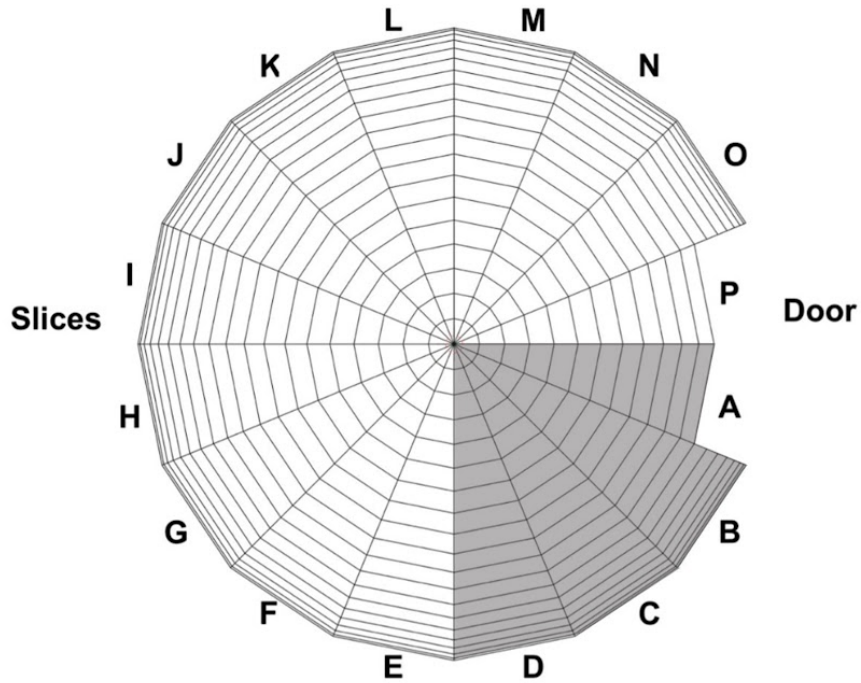

Floor SIDE VIEW

UPPER RIGHT SIDE BACK (SERVER RACK)

TOP VIEW

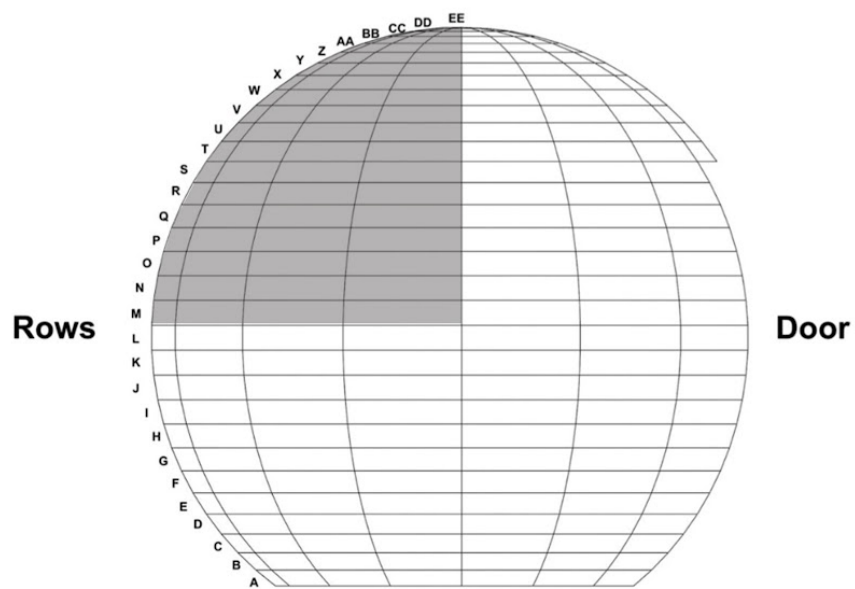
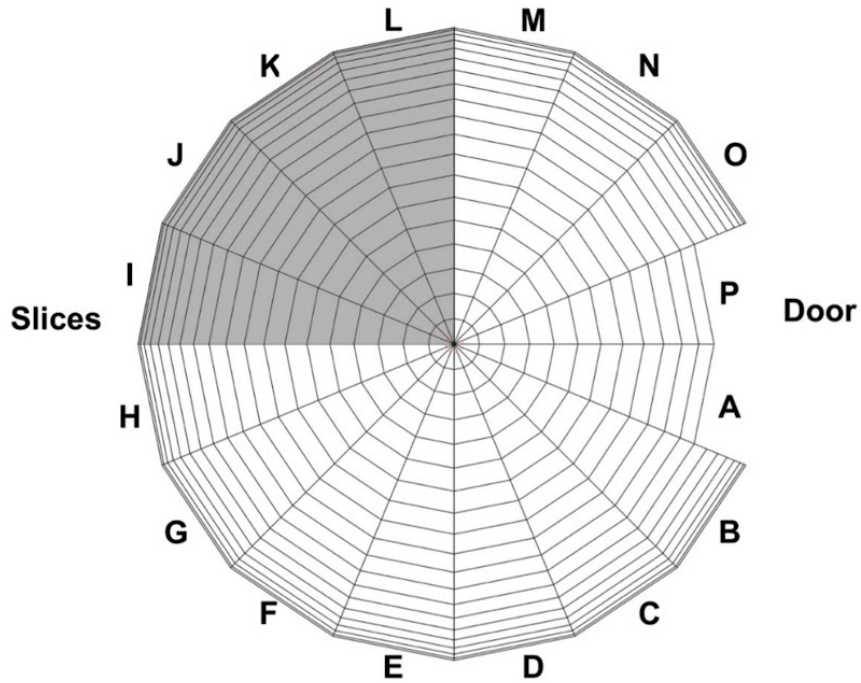

Floor SIDE VIEW

UPPER RIGHT SIDE FRONT (DOOR)

TOP VIEW

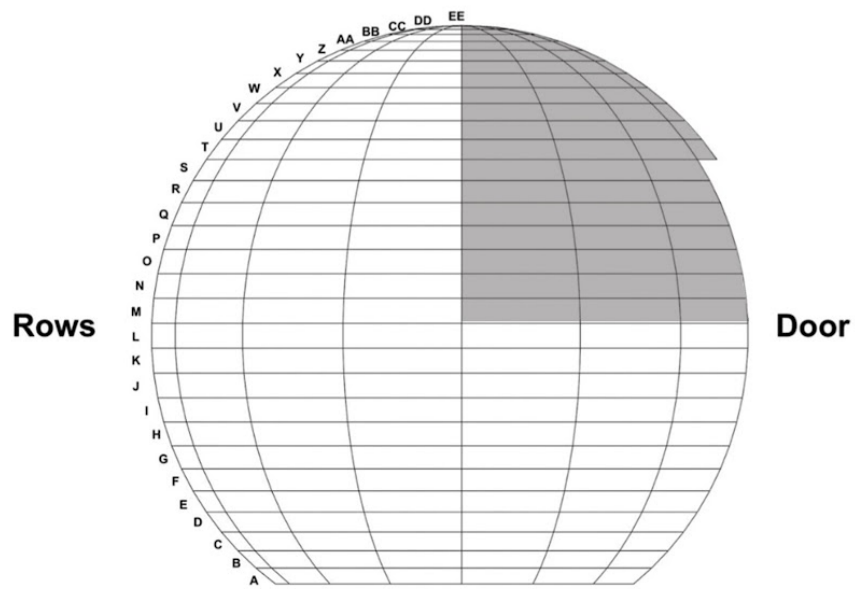
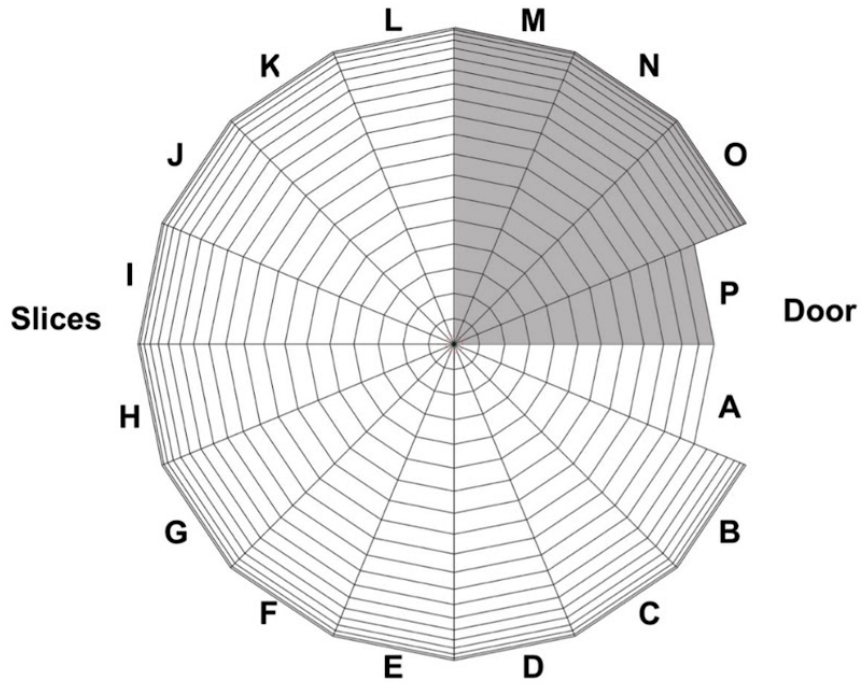

Floor SIDE VIEW

Dollies

While the sphere is dismantled in eights and dome, the cabling is organized per top hat and quarters. All cables are travelling disconnected from the patch bays. The speakers from the dome remained connected to their cable and the cable coils got packed within the dome crate. The speakers on the sphere's back eights remain connected to their cables while the speakers on the sphere's front eights get disconnected from their cables.

Dollies - a spoke centered on a plywood on wheel - are provided to group the cabling from each individual quarter: lower left side, lower right side, upper left side and upper right side. All the cables from the front eights have been coiled and attached on the last slice's shelf from the matching back eights.

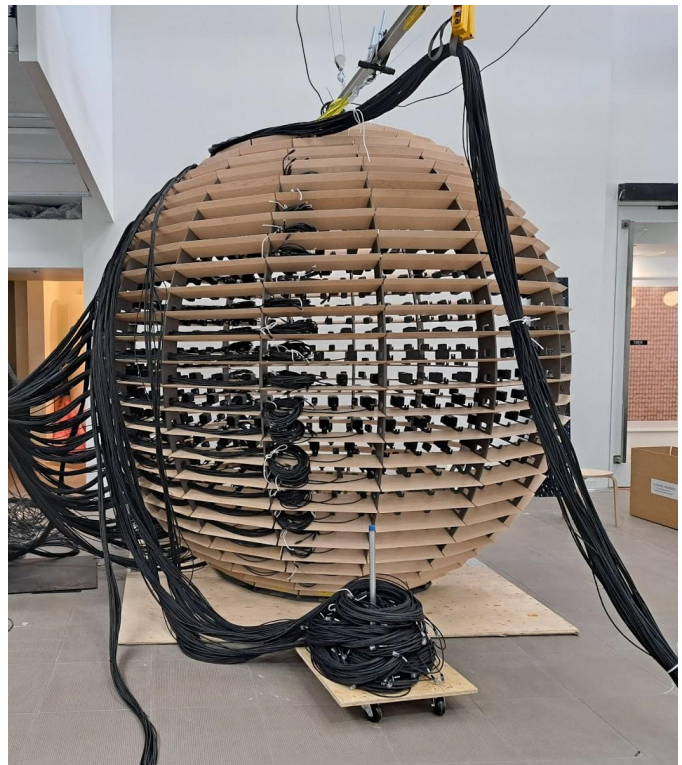

RAFAEL LOZANO HEMMER
SPHERE PACKING: BACH

LOWER LEFT SIDE

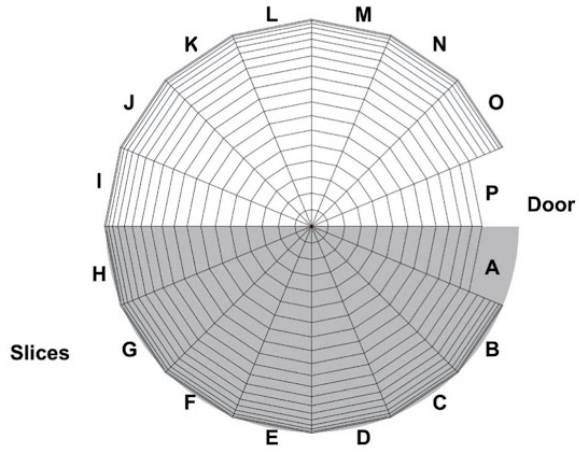

Top View

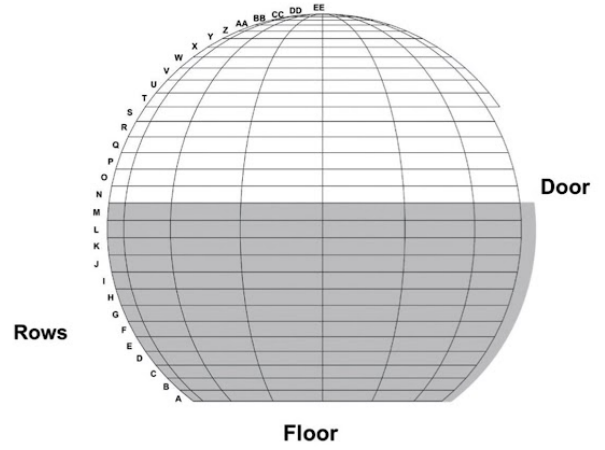

Side View

RAFAEL LOZANO HEMMER
SPHERE PACKING: BACH

LOWER RIGHT SIDE

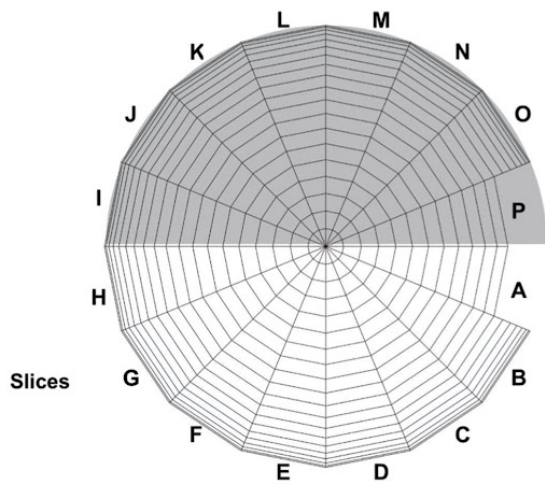

Top View

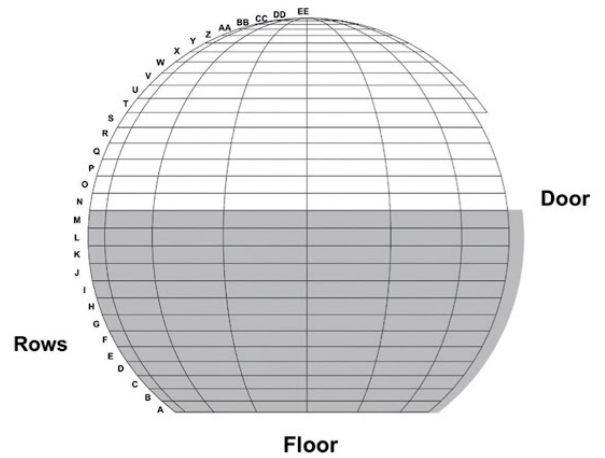

Side View

RAFAEL LOZANO HEMMER
SPHERE PACKING: BACH

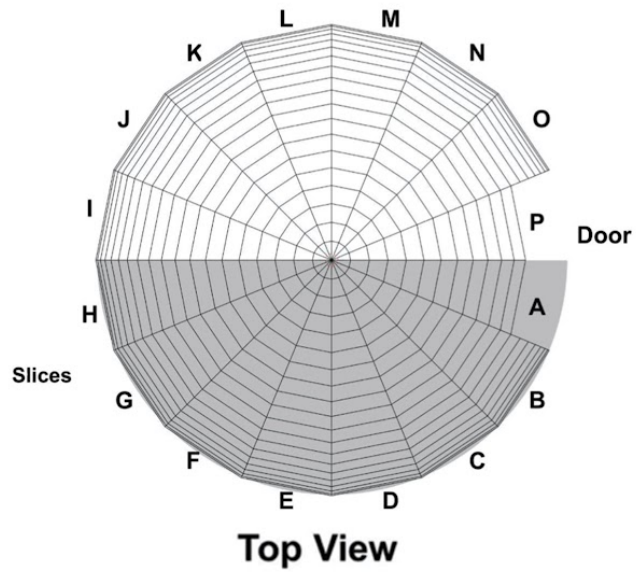

UPPER LEFT SIDE

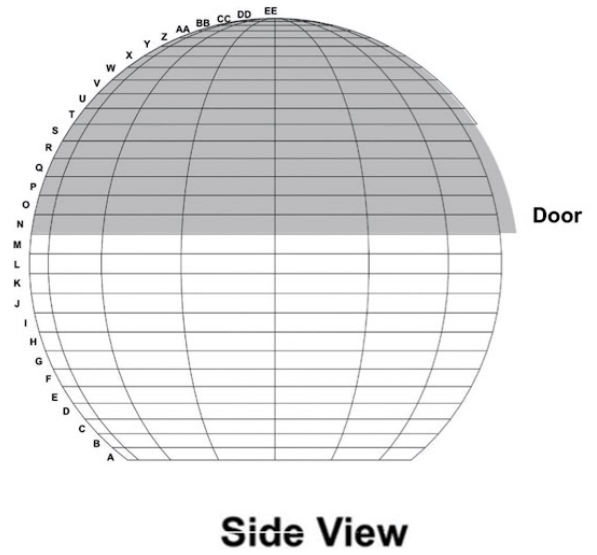

RAFAEL LOZANO HEMMER
SPHERE PACKING: BACH

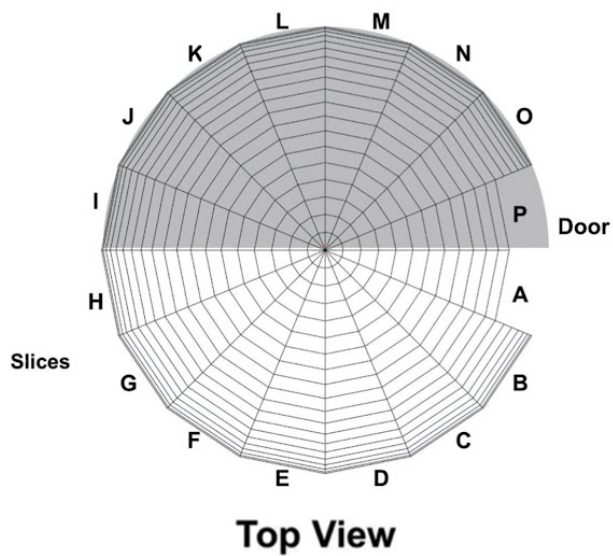

UPPER RIGHT SIDE

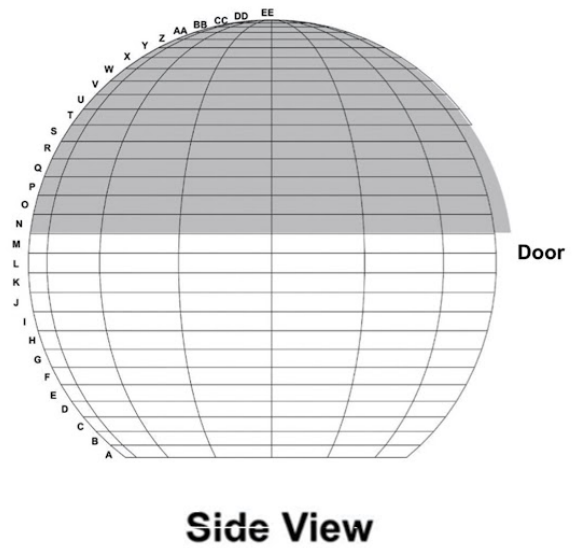

Patchbays - Components Details

REVISION HISTORY / HIST. REVISIONS

R0	2018/03/06	
R1	2018/03/20	
R2	2018/03/20	
R3	2023/03/02	
R4	YY/mm/dd	
R5	YY/mm/dd	
R6	YY/mm/dd	
R7	YY/mm/dd	
R8	YY/mm/dd	

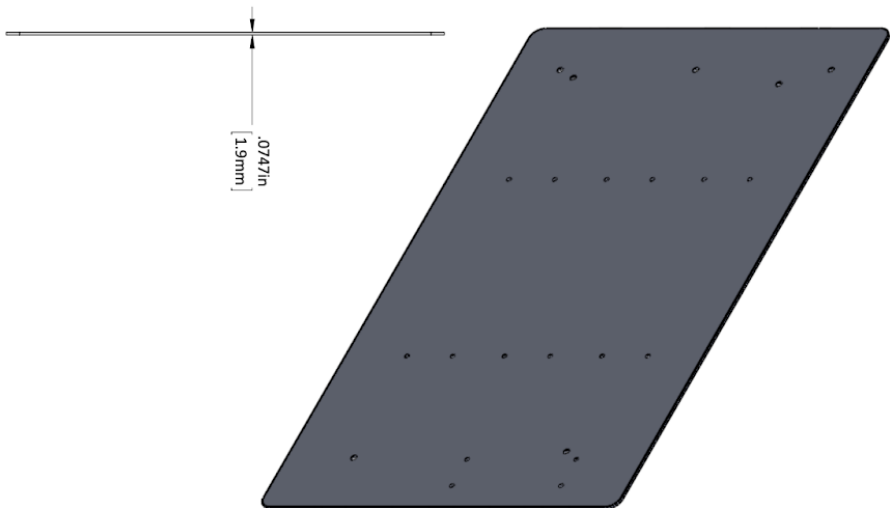
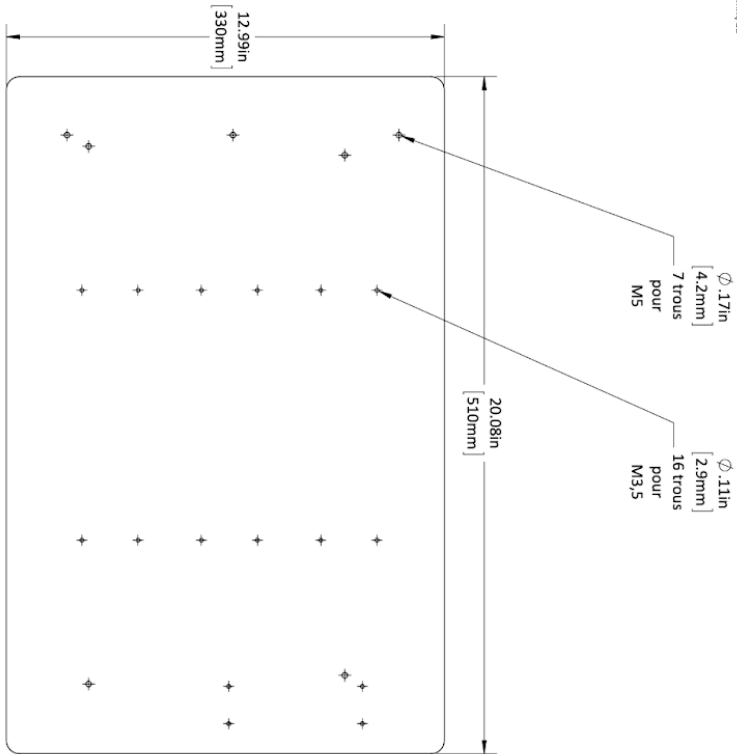

PROCÉDÉ / PROCESS
Découpe laser
 MATÉRIEL / MATERIAL
ACIER CRS 0.075"
14 gauge
 QUANTITÉS / QUANTITIES
3 X
 FINITION / FINISH
Bronze métallique
santex

générique
design

PROJECT / PROJET
BACH SPHERE
Réédition

CLIENT / CLIENT
ANTIMODULAR

PART NO. / PART NO.
P-244-907
PLAQUE PSU
dimensions

REVISION / RÉVISION
R3

SCALE / ÉCHELLE: **1:3**
 DRAWN BY / RÉVISÉ PAR: [blank]
 CHECKED BY / VÉRIFIÉ PAR: [blank]
 APPROVED BY / APPROUVÉ PAR: [blank]
 FIRM / ENTREPRISE: [blank]
 SKETCHED BY / ÉBROUSILLÉ PAR: [blank]
 APPROVED BY / APPROUVÉ PAR: [blank]
 FIRM / ENTREPRISE: [blank]



This drawing is confidential and must not be reproduced or used without the consent of GÉNÉRIQUE DESIGN Inc.

REVISION HISTORY / HIST. REVISIONS

R0	2018/03/06
R1	2018/03/20
R2	2018/03/26
R3	2018/03/26
R4	2018/03/26
R5	2018/03/26
R6	2018/03/26
R7	2018/03/26
R8	2018/03/26

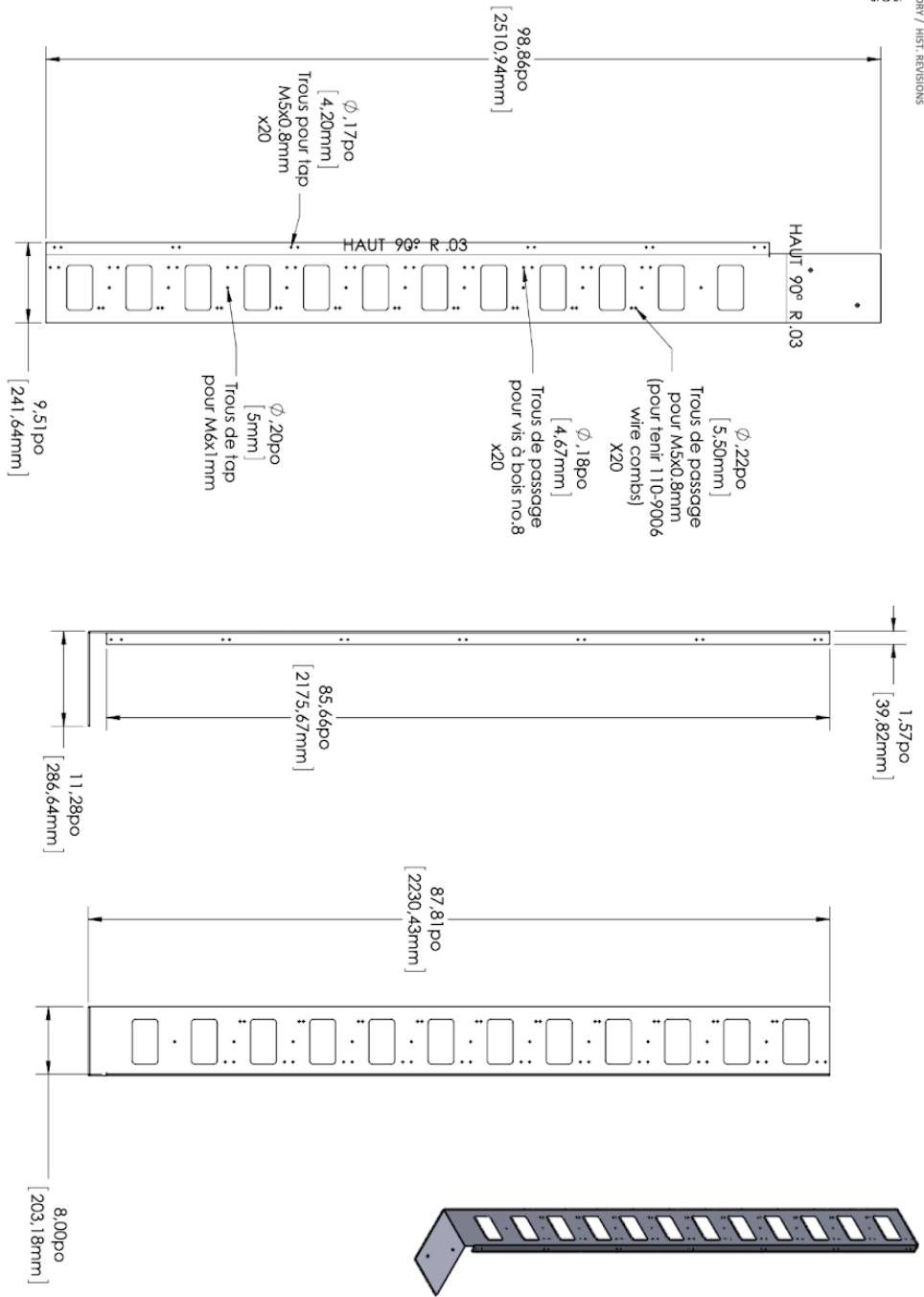

PROCESS / PROCESS
Découpe laser et pliage

MATERIAL / MATERIAL
Aluminium 3/16"

QUANTITIES / QUANTITIES
3 X PROD

FINISH / FINISH
Bronze metallic

generique
design

PROJECT / PROJET
BACH SPHERE
 Projet en developpement

CLIENT / CLIENT
ANTIMODULAR

PART NO. / PIÉCE NO.
P-110-9001-A
 Vert plié GAUCHE
 dimensions

REVISION / REVISION
R2

SCALE / ÉCHELLE: **1:12**

UNITS / UNITÉS: POUCES
 UNITS / UNITÉS: MILLIMÈTRES

DESIGNED BY / CONCEVU PAR: SKYLARK
 CHECKED BY / VÉRIFIÉ PAR: JANI SENKAL
 APPROVED BY / APPROUVÉ PAR: JANI SENKAL
 FINAL ENGINEER STRUCTURE: CONCEPT FABRICATION INC.

SHEET / FEUILLE: **1 of 6**

This drawing is confidential and must not be reproduced or used without the consent of GENERIQUE DESIGN Inc.

REVISION HISTORY / HIST. REVISIONS
 R0. 2018/03/06
 R1. 2018/03/25
 R2. 2018/03/25
 R3. yy/mm/dd
 R4. yy/mm/dd
 R5. yy/mm/dd
 R6. yy/mm/dd
 R7. yy/mm/dd
 R8. yy/mm/dd

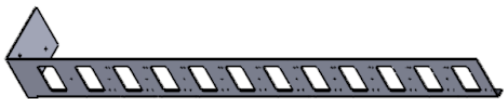
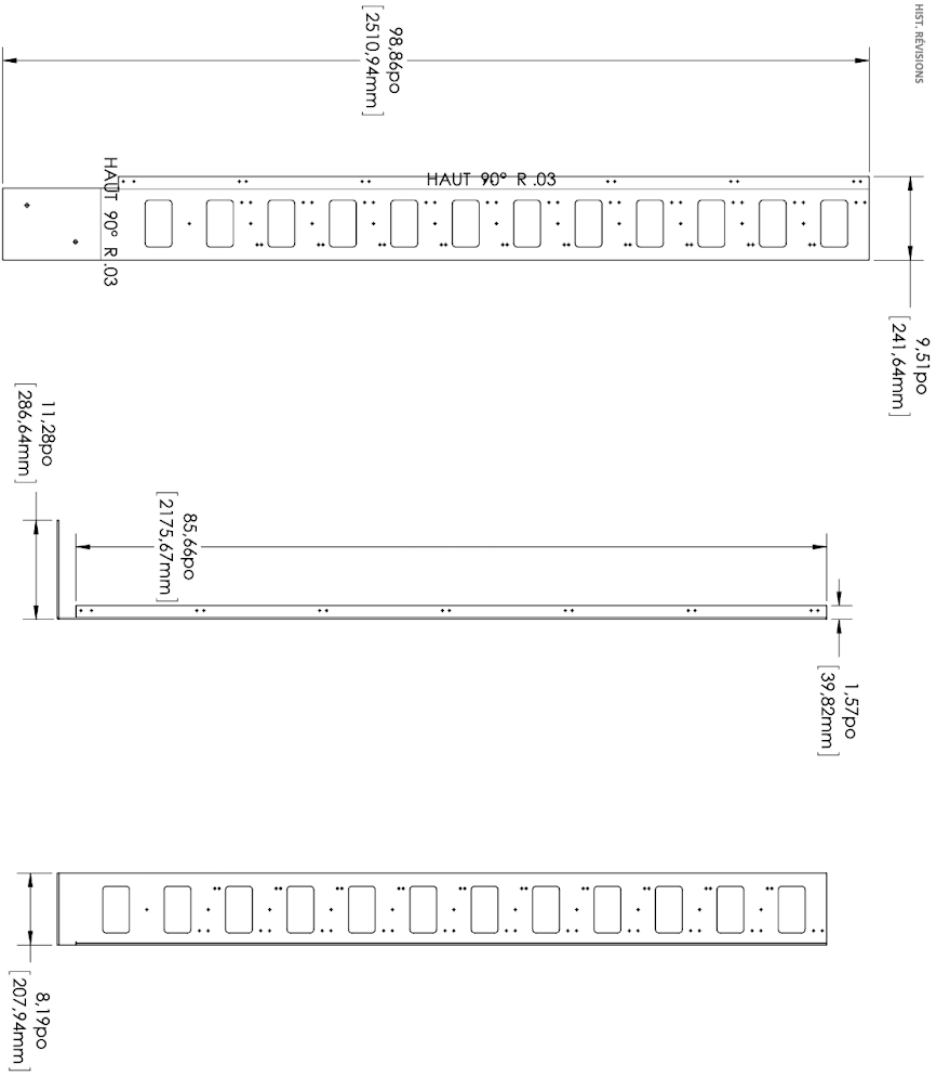

PRODUCÉ / PROCESS
**Découpe laser
 et pliage**
 MATÉRIEL / MATERIAL
**Aluminium 3/16"
 5052-H32**
 QUANTITÉS / QUANTITIES
3 X PROD
 FINITION / FINISH
**Bronze metallic
 santex**

générique
 design

PROJET / PROJET
BACH SPHERE
 Projet en développement

CLIENT / CLIENT
ANTIMODULAR

PART NO / PIÈCE NO.
P-110-9001-B
 VERT PILE DROITE
dimensions

REVISION / REVISION
R2

SCALE / ÉCHELLE **1:12**
 UNITS / UNITÉS: INCHES
 UNITS / UNITÉS: MILLIMÈTRES
 DRAWN BY / ASSISÉ PAR
 APPROVED BY / APPROUVÉ PAR: JEAN-PIERRE
 PHASE: MECHANICAL STRUCTURE: CONCEPT: PARADIGM INC.

SHEET / FEUILLE **2 of 6**

REVISION HISTORY / HIST. REVISIONS
 R0 2018/03/06
 R1 2018/03/20
 R2 2018/03/26
 R3 Y/mm/dd
 R4 Y/mm/dd
 R5 Y/mm/dd
 R6 Y/mm/dd
 R7 Y/mm/dd

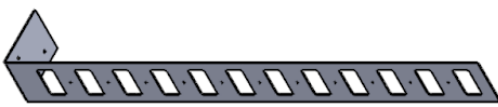
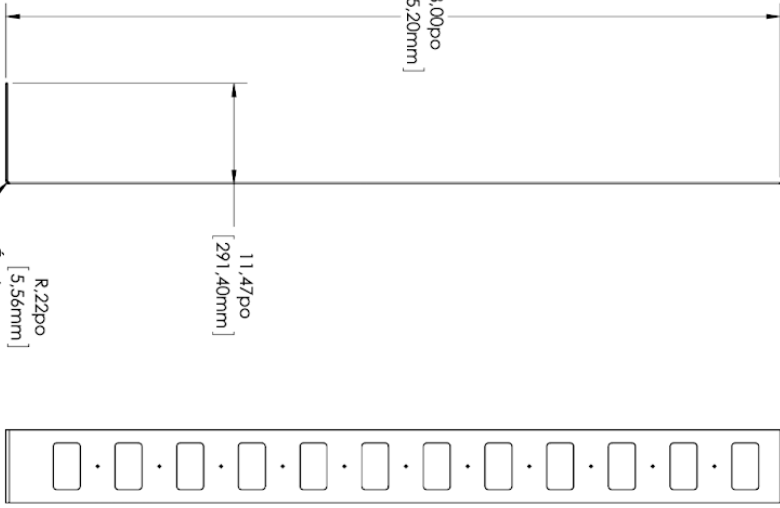
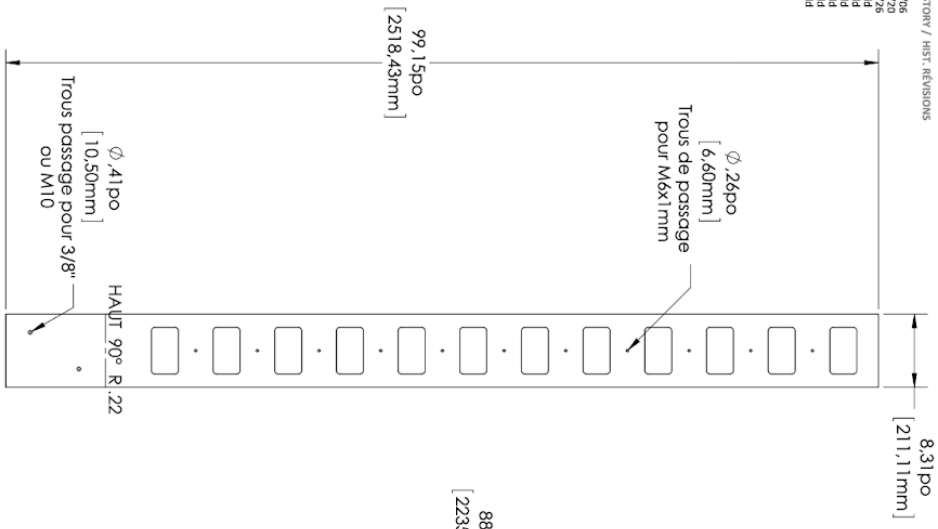

PROCEDE / PROCESS
Découpe laser
 et pliage
 MATÉRIEL / MATERIAL
Aluminium 3/16"
 5052-H32
 QUANTITÉS / QUANTITIES
6 X PROD
 FINITION / FINISH
Bronze métallique
 santex

générique
 design

PROJECT / PROJET
BACH SPHERE
 Projet en développement

CLIENT / CLIENT
ANTIMODULAR

PART NO. / PIÈCE NO.
P-110-9002
 VERT PUÉ EXTERNE
 dimensions

REVISION / RÉVISION
R2

SCALE / ÉCHELLE: **1:12**
 UNITS / UNITÉS: POUCES
 DIMENSIONS / DIMENSIONS: MILLIMÈTRES
 DRAWN BY / TRACÉ PAR: SKM/AMR
 APPROVED BY / APPROUVÉ PAR: JEAN-RENÉ LUD
 HEAD ENGINEER STRUCTURE: CONCEPT MANAGER INC.

SHEET / FEUILLE: **3 of 6**

REVISION HISTORY / HIST. REVISIONS

R0. 2018/03/06
 R1. 2018/03/20
 R2. 2018/03/25
 R3. v1/rev/dde
 R4. v1/rev/dde
 R5. v1/rev/dde
 R6. v1/rev/dde
 R7. v1/rev/dde
 R8. v1/rev/dde

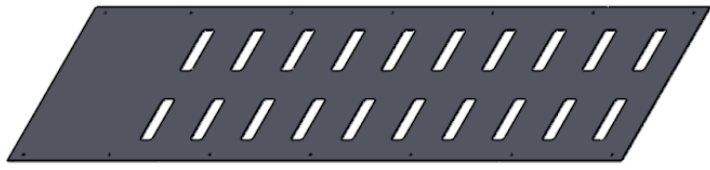
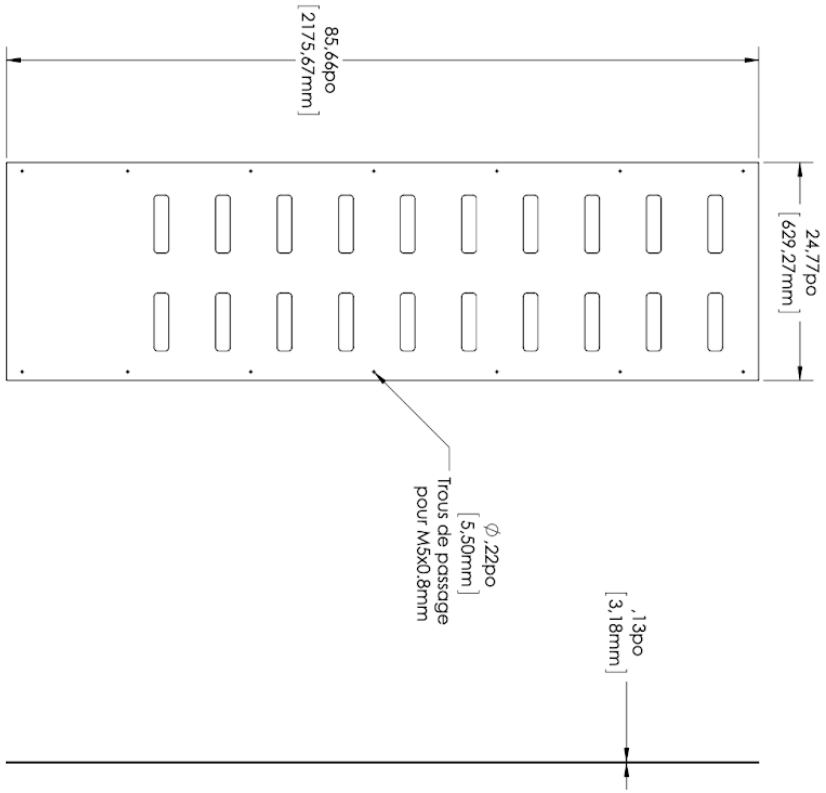

PROCESS / PROCESS
Découpe laser

MATERIAL / MATERIAL
Aluminium 1/8"
5052-H32

QUANTITIES / QUANTITIES
3 X PROD

FINISH / FINISH
Bronze metallic
santex

**generique
 design**

PROJECT / PROJET
BACH SPHERE
 Projet en développement

CLIENT / CLIENT
ANTIMODULAR

PART NO. / PIECE NO.
P-110-9004
 PLAQUE ARRIERE
dimensions

REVISION / REVISION
R2

SCALE / ECHELLE: **1:12**

UNITS / UNITES: POUCES
 DIMENSIONS / DIMENSIONS: INCHES
 DRAWN BY / Dessiné PAR: SKM/MLK
 CHECKED BY / Vérifié PAR: SKM/MLK
 APPROVED BY / Approuvé PAR: JEAN RENAUD
 PRINT INSTITUTE STRUCTURE: CONCEPT FABRICATION INC.

SHEET / FEUILLE: **5 of 6**

This drawing is confidential and must not be reproduced or used without the consent of GENERIQUE DESIGN Inc.

REVISION HISTORY / HIST. REVISIONS

R0. 2018/03/16
 R1. Y/mm/dd
 R2. Y/mm/dd
 R3. Y/mm/dd
 R4. Y/mm/dd
 R5. Y/mm/dd
 R6. Y/mm/dd
 R7. Y/mm/dd
 R8. Y/mm/dd



PROCEDE / PROCESS
Decoupe Laser

MATIERE / MATERIAL
Aluminium 1/2"
5052-H32

QUANTITES / QUANTITIES
32 X PROD

FINITION / FINISH
Bronze metallic

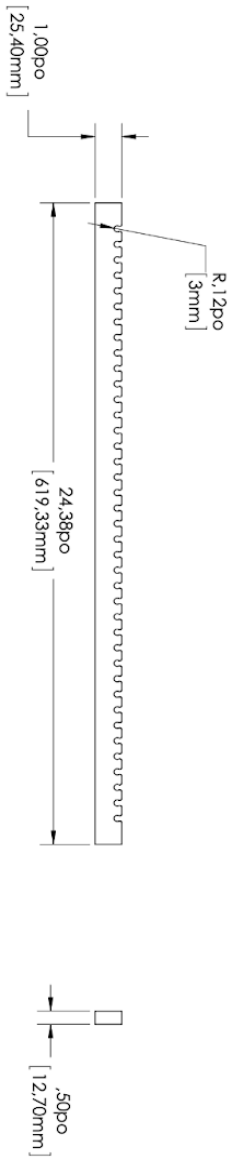

generique
 design

PROJECT / PROJET:
BACH SPHERE
 Projet en developpement

CLIENT / CLIENT:
ANTIMODULAR

PART NO. / PIECE NO.
P-110-9006
 Wire comb
 dimensions

REVISION / REVISION:
R0

SCALE / ECHELLE: **1:4**

UNITS / UNITS: POUCHES
 DIMENSIONS / DIMENSIONS: MILLIMETER
 DRAWN BY / DRESSÉ PAR: JENNY HANAU
 APPROVED BY / APPROUVÉ PAR: JENNY HANAU
 FIRM / ENGINEER STRUCTURE: CONCRETE MANAGEMENT, INC.

SHEET / FEUILLE: **1 of 1**

REVISION HISTORY / HIST. REVISIONS

R0.	2018/03/07
R1.	yy/mm/dd
R2.	yy/mm/dd
R3.	yy/mm/dd
R4.	yy/mm/dd
R5.	yy/mm/dd
R6.	yy/mm/dd
R7.	yy/mm/dd
R8.	yy/mm/dd

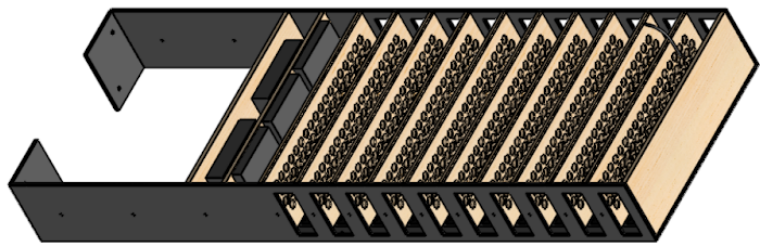
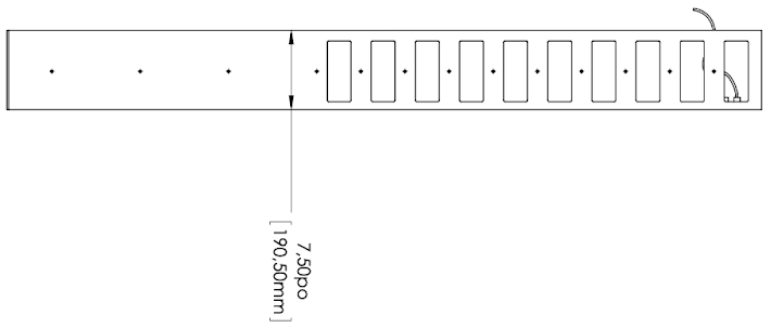
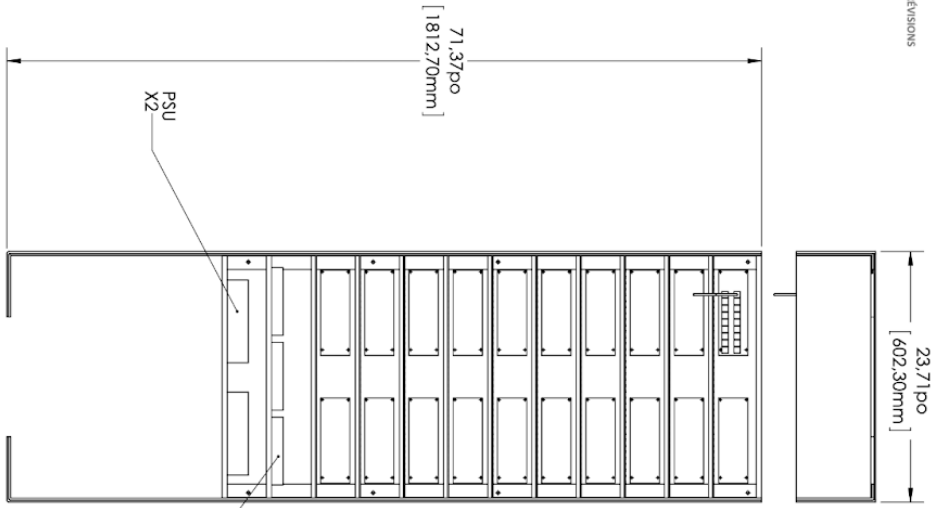

generique
design

PROJECT / PROJET
BACH SPHERE
Projet en developpement

CLIENT / CLIENT
ANTIMODULAR

PART NO. / PIÈCE NO.
P-110-9000
Bach plate
dimensions

REVISION / REVISION
R0

SCALE / ÉCHELLE: **1:10**

UNIT / UNITÉ: POUCES
DIMENSION / DIMENSION: MILLIMÈTRES
DESIGNED BY / CONCEVU PAR: SKANLAK
APPROVED BY / APPROUVÉ PAR: JEAN RENAUD
FIRM ENGINEER STRUCTURE: CONCEPT MANAGEMENT INC.

SHEET / FEUILLE: **1 of 1**

This drawing is confidential and must not be reproduced or used without the consent of GENERIQUE DESIGN INC.

REVISION HISTORY / HIST. REVISIONS

NO.	2018/03/20
R1.	2018/03/27
R2.	Y/m/m/dd
R3.	Y/m/m/dd
R4.	Y/m/m/dd
R5.	Y/m/m/dd
R6.	Y/m/m/dd
R7.	Y/m/m/dd
R8.	Y/m/m/dd

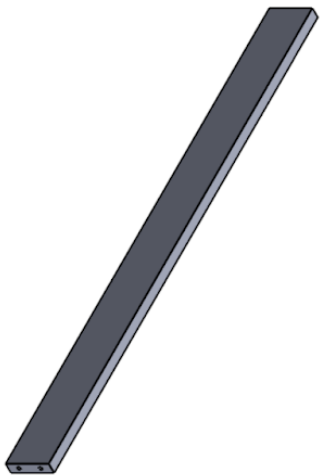

PROCÉDÉ / PROCESS
Découpe CNC
 ou banc de scie

MATÉRIEL / MATERIAL
Érable à sucre
Épaisseur 1/2"

QUANTITÉS / QUANTITIES
32 X PROD

FINITION / FINISH
Vernis clair
Base d'eau
(idem à
Bach Sphere)

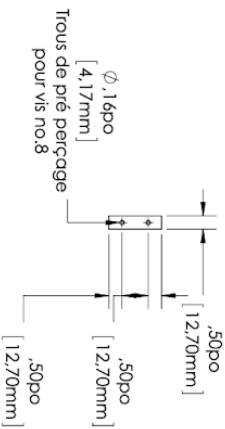
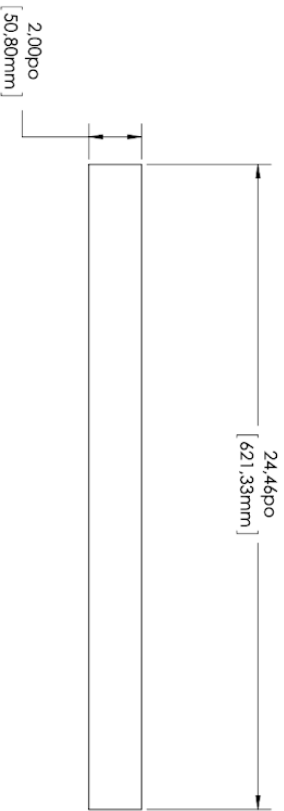

généricque
 design

PROJECT / PROJET
BACH SPHERE
 Projet en développement

CLIENT / CLIENT
ANTIMODULAR

PART NO. / PIÈCE NO.
P-110-9006
 Bois indicatif
dimensions

REVISION / REVISION
R1

SCALE / ÉCHELLE: **1:4**

UNITS / UNITÉS: **POUCES**
 UNITS / UNITÉS: **MILLIMÈTRES**

DESIGNED BY / CONCEPTÉ PAR: **SCOTT BARKER**
 APPROVED BY / APPROUVÉ PAR: **JEAN-EMILIO SANTIAGO**

FIRM ENGINEERING STRUCTURE: **CONCEPT PAKADISIGN INC.**

SHEET / FEUILLE: **1 of 1**

This drawing is confidential and must not be reproduced or used without the consent of GENERIQUE DESIGN Inc.

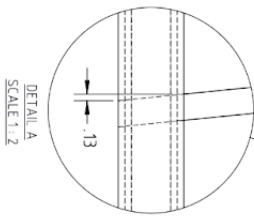
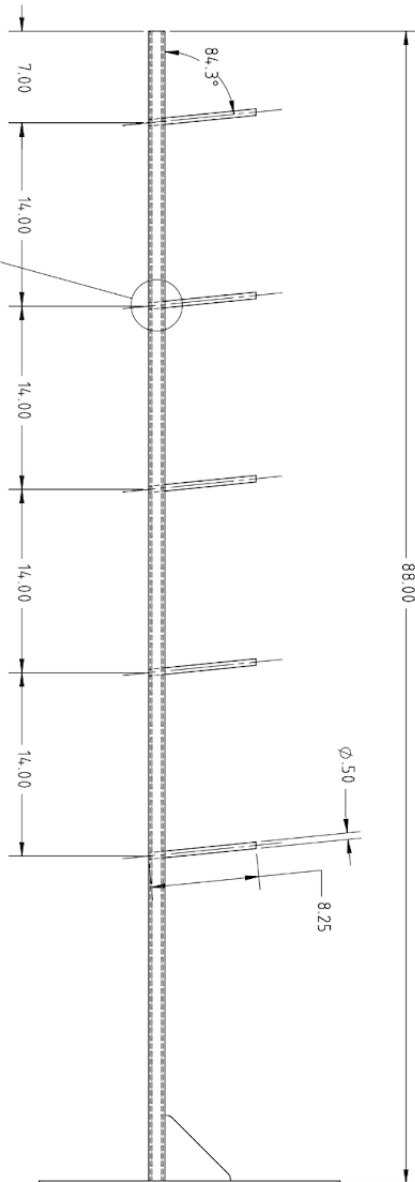
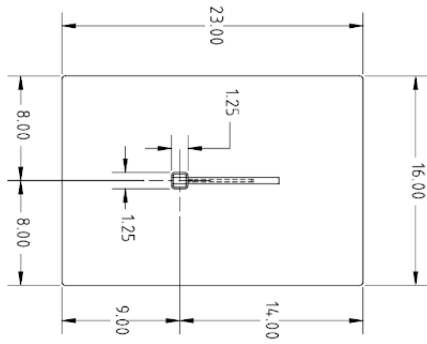

generique
design

CLIENT
ANTIMODULAR
PROJECT PRODUCT
BACH SPHERE
2022

DESIGN DRAWING
P-244-901
TITLE TITLE
COAT HANGER
DIMENSIONS

REVISION REFERENCE
R0
DATE
2022/11/24
DESIGNED BY
J.L.

PROCESS
FABRICATION
MATERIAL
ACIER
QUANTITY
4 X
FUNCTION
PTB6794 TEXTURED BRONZE

SCALE
UNITS
DIMENSIONS
1:8
PAPER NUMBER
1001
PAGE
1/1

CE Dessin est strictement confidentiel et ne doit pas être reproduit ou utilisé sans le consentement écrit de Generique Design Inc. THIS DRAWING IS STRICTLY CONFIDENTIAL AND MUST NOT BE REPRODUCED OR USED WITHOUT THE WRITTEN CONSENT OF GENERIQUE DESIGN INC.

Speakers: Position in Sphere, Label, Controller Connection and Cable Length

The labeling system for ethernet cords works as follows. Each cable is labeled **ROW-ROW_INDEX-SLICE-SPEAKER_INDEX**

rows start at a at the bottom and go upwards through the alphabet, because the sphere has more than 30 levels we begin to double letters, so after z it goes on to aa.

row_index indicates which speaker in the row it is starting clockwise from the door.

slice indicates which of the 16 vertical sections it is in

Speaker_index tells us where a speaker is when going clockwise from the beginning of its own slice. This can help you track a cable more quickly than counting clockwise around the entire sphere will allow.

This table gives you

Row	rowIndex	Label	Slice	Speaker Index	grpIndex	Row total	Controller ID	Channel	Cable Length
A	1	A0-C0	C	0	0	19	0	0	9m
A	1	A1-C1	C	1	1	19	0	1	9m
A	1	A2-D0	D	2	2	19	0	2	9m
A	1	A3-E0	E	3	3	19	0	3	9m
A	1	A4-E1	E	4	4	19	0	4	9m
A	1	A5-F0	F	5	5	19	0	5	8m
A	1	A6-G0	G	6	6	19	0	6	8m
A	1	A7-G1	G	7	7	19	0	7	8m
A	1	A8-H0	H	8	8	19	0	8	7m
A	1	A9-H1	H	9	9	19	0	9	7m
A	1	A10-I0	I	10	10	19	0	10	7m
A	1	A11-J0	J	11	11	19	0	11	8m
A	1	A12-J1	J	12	12	19	0	12	8m
A	1	A13-K0	K	13	13	19	0	13	8m
A	1	A14-L0	L	14	14	19	0	14	9m
A	1	A15-L1	L	15	15	19	0	15	9m
A	1	A16-M0	M	16	16	19	0	16	9m
A	1	A17-N0	N	17	17	19	0	17	9m
A	1	A18-N1	N	18	18	19	0	18	9m

Row	RowIndex	Label	Slice	Speaker Index	grpIndex	Row total	Controller ID	Channel	Cable Length
B	2	B0-B0	B	19	0	24	0	19	10m
B	2	B1-C0	C	20	1	24	0	20	9m
B	2	B2-C1	C	21	2	24	0	21	9m
B	2	B3-D0	D	22	3	24	0	22	9m
B	2	B4-D1	D	23	4	24	0	23	9m
B	2	B5-E0	E	24	5	24	1	0	9m
B	2	B6-E1	E	25	6	24	1	1	9m
B	2	B7-F0	F	26	7	24	1	2	8m
B	2	B8-G0	G	27	8	24	1	3	8m
B	2	B9-G1	G	28	9	24	1	4	8m
B	2	B10-H0	H	29	10	24	1	5	7m
B	2	B11-H1	H	30	11	24	1	6	7m
B	2	B12-I0	I	31	12	24	1	7	7m
B	2	B13-I1	I	32	13	24	1	8	7m
B	2	B14-J0	J	33	14	24	1	9	8m
B	2	B15-J1	J	34	15	24	1	10	8m
B	2	B16-K0	K	35	16	24	1	11	8m
B	2	B17-K1	K	36	17	24	1	12	8m
B	2	B18-L0	L	37	18	24	1	13	9m
B	2	B19-M0	M	38	19	24	1	14	9m
B	2	B20-M1	M	39	20	24	1	15	9m
B	2	B21-N0	N	40	21	24	1	16	9m
B	2	B22-N1	N	41	22	24	1	17	9m
B	2	B23-O0	O	42	23	24	1	18	10m
C	3	C0-B0	B	43	0	27	1	19	10m
C	3	C1-C0	C	44	1	27	1	20	9m
C	3	C2-C1	C	45	2	27	1	21	9m
C	3	C3-D0	D	46	3	27	1	22	9m
C	3	C4-D1	D	47	4	27	1	23	9m
C	3	C5-E0	E	48	5	27	2	0	9m
C	3	C6-E1	E	49	6	27	2	1	9m
C	3	C7-F0	F	50	7	27	2	2	8m
C	3	C8-F1	F	51	8	27	2	3	8m
C	3	C9-G0	G	52	9	27	2	4	8m
C	3	C10-G1	G	53	10	27	2	5	8m
C	3	C11-H0	H	54	11	27	2	6	7m

Row	rowIndex	Label	Slice	Speaker Index	grpIndex	Row total	Controller ID	Channel	Cable Length
C	3	C12-H1	H	55	12	27	2	7	7m
C	3	C13-H2	H	56	13	27	2	8	7m
C	3	C14-I0	I	57	14	27	2	9	7m
C	3	C15-I1	I	58	15	27	2	10	7m
C	3	C16-J0	J	59	16	27	2	11	8m
C	3	C17-J1	J	60	17	27	2	12	8m
C	3	C18-K0	K	61	18	27	2	13	8m
C	3	C19-K1	K	62	19	27	2	14	8m
C	3	C20-L0	L	63	20	27	2	15	9m
C	3	C21-L1	L	64	21	27	2	16	9m
C	3	C22-M0	M	65	22	27	2	17	9m
C	3	C23-M1	M	66	23	27	2	18	9m
C	3	C24-N0	N	67	24	27	2	19	9m
C	3	C25-N1	N	68	25	27	2	20	9m
C	3	C26-O0	O	69	26	27	2	21	10m
D	4	D0-B0	B	70	0	30	2	22	10m
D	4	D1-B1	B	71	1	30	2	23	10m
D	4	D2-C0	C	72	2	30	3	0	9m
D	4	D3-C1	C	73	3	30	3	1	9m
D	4	D4-D0	D	74	4	30	3	2	9m
D	4	D5-D1	D	75	5	30	3	3	9m
D	4	D6-E0	E	76	6	30	3	4	9m
D	4	D7-E1	E	77	7	30	3	5	9m
D	4	D8-F0	F	78	8	30	3	6	8m
D	4	D9-F1	F	79	9	30	3	7	8m
D	4	D10-F2	F	80	10	30	3	8	8m
D	4	D11-G0	G	81	11	30	3	9	8m
D	4	D12-G1	G	82	12	30	3	10	8m
D	4	D13-H0	H	83	13	30	3	11	7m
D	4	D14-H1	H	84	14	30	3	12	7m
D	4	D15-I0	I	85	15	30	3	13	7m
D	4	D16-I1	I	86	16	30	3	14	7m
D	4	D17-J0	J	87	17	30	3	15	8m
D	4	D18-J1	J	88	18	30	3	16	8m
D	4	D19-K0	K	89	19	30	3	17	8m
D	4	D20-K1	K	90	20	30	3	18	8m

Row	RowIndex	Label	Slice	Speaker Index	grpIndex	Row total	Controller ID	Channel	Cable Length
D	4	D21-K2	K	91	21	30	3	19	8m
D	4	D22-L0	L	92	22	30	3	20	9m
D	4	D23-L1	L	93	23	30	3	21	9m
D	4	D24-M0	M	94	24	30	3	22	9m
D	4	D25-M1	M	95	25	30	3	23	9m
D	4	D26-N0	N	96	26	30	4	0	9m
D	4	D27-N1	N	97	27	30	4	1	9m
D	4	D28-O0	O	98	28	30	4	2	10m
D	4	D29-O1	O	99	29	30	4	3	10m
E	5	E0-B0	B	100	0	33	4	4	10m
E	5	E1-B1	B	101	1	33	4	5	10m
E	5	E2-C0	C	102	2	33	4	6	9m
E	5	E3-C1	C	103	3	33	4	7	9m
E	5	E4-D0	D	104	4	33	4	8	9m
E	5	E5-D1	D	105	5	33	4	9	9m
E	5	E6-D2	D	106	6	33	4	10	9m
E	5	E7-E0	E	107	7	33	4	11	9m
E	5	E8-E1	E	108	8	33	4	12	9m
E	5	E9-F0	F	109	9	33	4	13	8m
E	5	E10-F1	F	110	10	33	4	14	8m
E	5	E11-F2	F	111	11	33	4	15	8m
E	5	E12-G0	G	112	12	33	4	16	8m
E	5	E13-G1	G	113	13	33	4	17	8m
E	5	E14-H0	H	114	14	33	4	18	7m
E	5	E15-H1	H	115	15	33	4	19	7m
E	5	E16-H2	H	116	16	33	4	20	7m
E	5	E17-I0	I	117	17	33	4	21	7m
E	5	E18-I1	I	118	18	33	4	22	7m
E	5	E19-J0	J	119	19	33	4	23	8m
E	5	E20-J1	J	120	20	33	5	0	8m
E	5	E21-K0	K	121	21	33	5	1	8m
E	5	E22-K1	K	122	22	33	5	2	8m
E	5	E23-K2	K	123	23	33	5	3	8m
E	5	E24-L0	L	124	24	33	5	4	9m
E	5	E25-L1	L	125	25	33	5	5	9m
E	5	E26-M0	M	126	26	33	5	6	9m

Row	RowIndex	Label	Slice	Speaker Index	grpIndex	Row total	Controller ID	Channel	Cable Length
E	5	E27-M1	M	127	27	33	5	7	9m
E	5	E28-M2	M	128	28	33	5	8	9m
E	5	E29-N0	N	129	29	33	5	9	9m
E	5	E30-N1	N	130	30	33	5	10	9m
E	5	E31-O0	O	131	31	33	5	11	10m
E	5	E32-O1	O	132	32	33	5	12	10m
F	6	F0-B0	B	133	0	36	5	13	10m
F	6	F1-B1	B	134	1	36	5	14	10m
F	6	F2-C0	C	135	2	36	5	15	9m
F	6	F3-C1	C	136	3	36	5	16	9m
F	6	F4-C2	C	137	4	36	5	17	9m
F	6	F5-D0	D	138	5	36	5	18	9m
F	6	F6-D1	D	139	6	36	5	19	9m
F	6	F7-D2	D	140	7	36	5	20	9m
F	6	F8-E0	E	141	8	36	5	21	9m
F	6	F9-E1	E	142	9	36	5	22	9m
F	6	F10-F0	F	143	10	36	5	23	8m
F	6	F11-F1	F	144	11	36	6	0	8m
F	6	F12-F2	F	145	12	36	6	1	8m
F	6	F13-G0	G	146	13	36	6	2	8m
F	6	F14-G1	G	147	14	36	6	3	8m
F	6	F15-H0	H	148	15	36	6	4	7m
F	6	F16-H1	H	149	16	36	6	5	7m
F	6	F17-H2	H	150	17	36	6	6	7m
F	6	F18-I0	I	151	18	36	6	7	7m
F	6	F19-I1	I	152	19	36	6	8	7m
F	6	F20-I2	I	153	20	36	6	9	7m
F	6	F21-J0	J	154	21	36	6	10	8m
F	6	F22-J1	J	155	22	36	6	11	8m
F	6	F23-K0	K	156	23	36	6	12	8m
F	6	F24-K1	K	157	24	36	6	13	8m
F	6	F25-K2	K	158	25	36	6	14	8m
F	6	F26-L0	L	159	26	36	6	15	9m
F	6	F27-L1	L	160	27	36	6	16	9m
F	6	F28-M0	M	161	28	36	6	17	9m
F	6	F29-M1	M	162	29	36	6	18	9m

Row	rowIndex	Label	Slice	Speaker Index	grpIndex	Row total	Controller ID	Channel	Cable Length
F	6	F30-M2	M	163	30	36	6	19	9m
F	6	F31-N0	N	164	31	36	6	20	9m
F	6	F32-N1	N	165	32	36	6	21	9m
F	6	F33-N2	N	166	33	36	6	22	9m
F	6	F34-O0	O	167	34	36	6	23	10m
F	6	F35-O1	O	168	35	36	7	0	10m
G	7	G0-B0	B	169	0	39	7	1	10m
G	7	G1-B1	B	170	1	39	7	2	10m
G	7	G2-B2	B	171	2	39	7	3	10m
G	7	G3-C0	C	172	3	39	7	4	9m
G	7	G4-C1	C	173	4	39	7	5	9m
G	7	G5-C2	C	174	5	39	7	6	9m
G	7	G6-D0	D	175	6	39	7	7	9m
G	7	G7-D1	D	176	7	39	7	8	9m
G	7	G8-E0	E	177	8	39	7	9	9m
G	7	G9-E1	E	178	9	39	7	10	9m
G	7	G10-E2	E	179	10	39	7	11	9m
G	7	G11-F0	F	180	11	39	7	12	8m
G	7	G12-F1	F	181	12	39	7	13	8m
G	7	G13-F2	F	182	13	39	7	14	8m
G	7	G14-G0	G	183	14	39	7	15	8m
G	7	G15-G1	G	184	15	39	7	16	8m
G	7	G16-G2	G	185	16	39	7	17	8m
G	7	G17-H0	H	186	17	39	7	18	7m
G	7	G18-H1	H	187	18	39	7	19	7m
G	7	G19-H2	H	188	19	39	7	20	7m
G	7	G20-I0	I	189	20	39	7	21	7m
G	7	G21-I1	I	190	21	39	7	22	7m
G	7	G22-J0	J	191	22	39	7	23	8m
G	7	G23-J1	J	192	23	39	8	0	8m
G	7	G24-J2	J	193	24	39	8	1	8m
G	7	G25-K0	K	194	25	39	8	2	8m
G	7	G26-K1	K	195	26	39	8	3	8m
G	7	G27-K2	K	196	27	39	8	4	8m
G	7	G28-L0	L	197	28	39	8	5	9m
G	7	G29-L1	L	198	29	39	8	6	9m

Row	RowIndex	Label	Slice	Speaker Index	grpIndex	Row total	Controller ID	Channel	Cable Length
G	7	G30-L2	L	199	30	39	8	7	9m
G	7	G31-M0	M	200	31	39	8	8	9m
G	7	G32-M1	M	201	32	39	8	9	9m
G	7	G33-N0	N	202	33	39	8	10	9m
G	7	G34-N1	N	203	34	39	8	11	9m
G	7	G35-N2	N	204	35	39	8	12	9m
G	7	G36-O0	O	205	36	39	8	13	10m
G	7	G37-O1	O	206	37	39	8	14	10m
G	7	G38-O2	O	207	38	39	8	15	10m
H	8	H0-B0	B	208	0	40	8	16	10m
H	8	H1-B1	B	209	1	40	8	17	10m
H	8	H2-B2	B	210	2	40	8	18	10m
H	8	H3-C0	C	211	3	40	8	19	9m
H	8	H4-C1	C	212	4	40	8	20	9m
H	8	H5-D0	D	213	5	40	8	21	9m
H	8	H6-D1	D	214	6	40	8	22	9m
H	8	H7-D2	D	215	7	40	8	23	9m
H	8	H8-E0	E	216	8	40	9	0	9m
H	8	H9-E1	E	217	9	40	9	1	9m
H	8	H10-E2	E	218	10	40	9	2	9m
H	8	H11-F0	F	219	11	40	9	3	8m
H	8	H12-F1	F	220	12	40	9	4	8m
H	8	H13-F2	F	221	13	40	9	5	8m
H	8	H14-G0	G	222	14	40	9	6	8m
H	8	H15-G1	G	223	15	40	9	7	8m
H	8	H16-G2	G	224	16	40	9	8	8m
H	8	H17-H0	H	225	17	40	9	9	7m
H	8	H18-H1	H	226	18	40	9	10	7m
H	8	H19-H2	H	227	19	40	9	11	7m
H	8	H20-I0	I	228	20	40	9	12	7m
H	8	H21-I1	I	229	21	40	9	13	7m
H	8	H22-I2	I	230	22	40	9	14	7m
H	8	H23-J0	J	231	23	40	9	15	8m
H	8	H24-J1	J	232	24	40	9	16	8m
H	8	H25-J2	J	233	25	40	9	17	8m
H	8	H26-K0	K	234	26	40	9	18	8m

Row	RowIndex	Label	Slice	Speaker Index	grpIndex	Row total	Controller ID	Channel	Cable Length
H	8	H27-K1	K	235	27	40	9	19	8m
H	8	H28-K2	K	236	28	40	9	20	8m
H	8	H29-L0	L	237	29	40	9	21	9m
H	8	H30-L1	L	238	30	40	9	22	9m
H	8	H31-L2	L	239	31	40	9	23	9m
H	8	H32-M0	M	240	32	40	10	0	9m
H	8	H33-M1	M	241	33	40	10	1	9m
H	8	H34-M2	M	242	34	40	10	2	9m
H	8	H35-N0	N	243	35	40	10	3	9m
H	8	H36-N1	N	244	36	40	10	4	9m
H	8	H37-O0	O	245	37	40	10	5	10m
H	8	H38-O1	O	246	38	40	10	6	10m
H	8	H39-O2	O	247	39	40	10	7	10m
I	9	I0-B0	B	248	0	41	10	8	10m
I	9	I1-B1	B	249	1	41	10	9	10m
I	9	I2-C0	C	250	2	41	10	10	9m
I	9	I3-C1	C	251	3	41	10	11	9m
I	9	I4-C2	C	252	4	41	10	12	9m
I	9	I5-D0	D	253	5	41	10	13	9m
I	9	I6-D1	D	254	6	41	10	14	9m
I	9	I7-D2	D	255	7	41	10	15	9m
I	9	I8-E0	E	256	8	41	10	16	9m
I	9	I9-E1	E	257	9	41	10	17	9m
I	9	I10-E2	E	258	10	41	10	18	9m
I	9	I11-F0	F	259	11	41	10	19	8m
I	9	I12-F1	F	260	12	41	10	20	8m
I	9	I13-F2	F	261	13	41	10	21	8m
I	9	I14-G0	G	262	14	41	10	22	8m
I	9	I15-G1	G	263	15	41	10	23	8m
I	9	I16-G2	G	264	16	41	11	0	8m
I	9	I17-H0	H	265	17	41	11	1	7m
I	9	I18-H1	H	266	18	41	11	2	7m
I	9	I19-H2	H	267	19	41	11	3	7m
I	9	I20-H3	H	268	20	41	11	4	7m
I	9	I21-I0	I	269	21	41	11	5	7m
I	9	I22-I1	I	270	22	41	11	6	7m

Row	rowIndex	Label	Slice	Speaker Index	grpIndex	Row total	Controller ID	Channel	Cable Length
I	9	I23-I2	I	271	23	41	11	7	7m
I	9	I24-J0	J	272	24	41	11	8	8m
I	9	I25-J1	J	273	25	41	11	9	8m
I	9	I26-J2	J	274	26	41	11	10	8m
I	9	I27-K0	K	275	27	41	11	11	8m
I	9	I28-K1	K	276	28	41	11	12	8m
I	9	I29-L0	L	277	29	41	11	13	9m
I	9	I30-L1	L	278	30	41	11	14	9m
I	9	I31-L2	L	279	31	41	11	15	9m
I	9	I32-L3	L	280	32	41	11	16	9m
I	9	I33-M0	M	281	33	41	11	17	9m
I	9	I34-M1	M	282	34	41	11	18	9m
I	9	I35-M2	M	283	35	41	11	19	9m
I	9	I36-N0	N	284	36	41	11	20	9m
I	9	I37-N1	N	285	37	41	11	21	9m
I	9	I38-N2	N	286	38	41	11	22	9m
I	9	I39-O0	O	287	39	41	11	23	10m
I	9	I40-O1	O	288	40	41	12	0	10m
J	10	J0-B0	B	289	0	42	12	1	10m
J	10	J1-B1	B	290	1	42	12	2	10m
J	10	J2-B2	B	291	2	42	12	3	10m
J	10	J3-C0	C	292	3	42	12	4	9m
J	10	J4-C1	C	293	4	42	12	5	9m
J	10	J5-C2	C	294	5	42	12	6	9m
J	10	J6-D0	D	295	6	42	12	7	9m
J	10	J7-D1	D	296	7	42	12	8	9m
J	10	J8-D2	D	297	8	42	12	9	9m
J	10	J9-E0	E	298	9	42	12	10	9m
J	10	J10-E1	E	299	10	42	12	11	9m
J	10	J11-E2	E	300	11	42	12	12	9m
J	10	J12-F0	F	301	12	42	12	13	8m
J	10	J13-F1	F	302	13	42	12	14	8m
J	10	J14-F2	F	303	14	42	12	15	8m
J	10	J15-G0	G	304	15	42	12	16	8m
J	10	J16-G1	G	305	16	42	12	17	8m
J	10	J17-G2	G	306	17	42	12	18	8m

Row	RowIndex	Label	Slice	Speaker Index	grpIndex	Row total	Controller ID	Channel	Cable Length
J	10	J18-H0	H	307	18	42	12	19	7m
J	10	J19-H1	H	308	19	42	12	20	7m
J	10	J20-H2	H	309	20	42	12	21	7m
J	10	J21-I0	I	310	21	42	12	22	7m
J	10	J22-I1	I	311	22	42	12	23	7m
J	10	J23-I2	I	312	23	42	13	0	7m
J	10	J24-J0	J	313	24	42	13	1	8m
J	10	J25-J1	J	314	25	42	13	2	8m
J	10	J26-J2	J	315	26	42	13	3	8m
J	10	J27-K0	K	316	27	42	13	4	8m
J	10	J28-K1	K	317	28	42	13	5	8m
J	10	J29-K2	K	318	29	42	13	6	8m
J	10	J30-L0	L	319	30	42	13	7	9m
J	10	J31-L1	L	320	31	42	13	8	9m
J	10	J32-L2	L	321	32	42	13	9	9m
J	10	J33-M0	M	322	33	42	13	10	9m
J	10	J34-M1	M	323	34	42	13	11	9m
J	10	J35-M2	M	324	35	42	13	12	9m
J	10	J36-N0	N	325	36	42	13	13	9m
J	10	J37-N1	N	326	37	42	13	14	9m
J	10	J38-N2	N	327	38	42	13	15	9m
J	10	J39-O0	O	328	39	42	13	16	10m
J	10	J40-O1	O	329	40	42	13	17	10m
J	10	J41-O2	O	330	41	42	13	18	10m
K	11	K0-B0	B	331	0	43	13	19	10m
K	11	K1-B1	B	332	1	43	13	20	10m
K	11	K2-B2	B	333	2	43	13	21	10m
K	11	K3-C0	C	334	3	43	13	22	9m
K	11	K4-C1	C	335	4	43	13	23	9m
K	11	K5-C2	C	336	5	43	14	0	9m
K	11	K6-D0	D	337	6	43	14	1	9m
K	11	K7-D1	D	338	7	43	14	2	9m
K	11	K8-D2	D	339	8	43	14	3	9m
K	11	K9-E0	E	340	9	43	14	4	9m
K	11	K10-E1	E	341	10	43	14	5	9m
K	11	K11-E2	E	342	11	43	14	6	9m

Row	rowIndex	Label	Slice	Speaker Index	grpIndex	Row total	Controller ID	Channel	Cable Length
K	11	K12-F0	F	343	12	43	14	7	8m
K	11	K13-F1	F	344	13	43	14	8	8m
K	11	K14-F2	F	345	14	43	14	9	8m
K	11	K15-G0	G	346	15	43	14	10	8m
K	11	K16-G1	G	347	16	43	14	11	8m
K	11	K17-G2	G	348	17	43	14	12	8m
K	11	K18-H0	H	349	18	43	14	13	7m
K	11	K19-H1	H	350	19	43	14	14	7m
K	11	K20-H2	H	351	20	43	14	15	7m
K	11	K21-H3	H	352	21	43	14	16	7m
K	11	K22-I0	I	353	22	43	14	17	7m
K	11	K23-I1	I	354	23	43	14	18	7m
K	11	K24-I2	I	355	24	43	14	19	7m
K	11	K25-J0	J	356	25	43	14	20	8m
K	11	K26-J1	J	357	26	43	14	21	8m
K	11	K27-J2	J	358	27	43	14	22	8m
K	11	K28-K0	K	359	28	43	14	23	8m
K	11	K29-K1	K	360	29	43	15	0	8m
K	11	K30-K2	K	361	30	43	15	1	8m
K	11	K31-L0	L	362	31	43	15	2	9m
K	11	K32-L1	L	363	32	43	15	3	9m
K	11	K33-L2	L	364	33	43	15	4	9m
K	11	K34-M0	M	365	34	43	15	5	9m
K	11	K35-M1	M	366	35	43	15	6	9m
K	11	K36-M2	M	367	36	43	15	7	9m
K	11	K37-N0	N	368	37	43	15	8	9m
K	11	K38-N1	N	369	38	43	15	9	9m
K	11	K39-N2	N	370	39	43	15	10	9m
K	11	K40-O0	O	371	40	43	15	11	10m
K	11	K41-O1	O	372	41	43	15	12	10m
K	11	K42-O2	O	373	42	43	15	13	10m
L	12	L0-B0	B	374	0	44	15	14	10m
L	12	L1-B1	B	375	1	44	15	15	10m
L	12	L2-B2	B	376	2	44	15	16	10m
L	12	L3-C0	C	377	3	44	15	17	9m
L	12	L4-C1	C	378	4	44	15	18	9m

Row	RowIndex	Label	Slice	Speaker Index	grpIndex	Row total	Controller ID	Channel	Cable Length
L	12	L5-C2	C	379	5	44	15	19	9m
L	12	L6-D0	D	380	6	44	15	20	9m
L	12	L7-D1	D	381	7	44	15	21	9m
L	12	L8-D2	D	382	8	44	15	22	9m
L	12	L9-E0	E	383	9	44	15	23	9m
L	12	L10-E1	E	384	10	44	16	0	9m
L	12	L11-E2	E	385	11	44	16	1	9m
L	12	L12-F0	F	386	12	44	16	2	8m
L	12	L13-F1	F	387	13	44	16	3	8m
L	12	L14-F2	F	388	14	44	16	4	8m
L	12	L15-F3	F	389	15	44	16	5	8m
L	12	L16-G0	G	390	16	44	16	6	8m
L	12	L17-G1	G	391	17	44	16	7	8m
L	12	L18-G2	G	392	18	44	16	8	8m
L	12	L19-H0	H	393	19	44	16	9	7m
L	12	L20-H1	H	394	20	44	16	10	7m
L	12	L21-H2	H	395	21	44	16	11	7m
L	12	L22-I0	I	396	22	44	16	12	7m
L	12	L23-I1	I	397	23	44	16	13	7m
L	12	L24-I2	I	398	24	44	16	14	7m
L	12	L25-J0	J	399	25	44	16	15	8m
L	12	L26-J1	J	400	26	44	16	16	8m
L	12	L27-J2	J	401	27	44	16	17	8m
L	12	L28-K0	K	402	28	44	16	18	8m
L	12	L29-K1	K	403	29	44	16	19	8m
L	12	L30-K2	K	404	30	44	16	20	8m
L	12	L31-K3	K	405	31	44	16	21	8m
L	12	L32-L0	L	406	32	44	16	22	9m
L	12	L33-L1	L	407	33	44	16	23	9m
L	12	L34-L2	L	408	34	44	17	0	9m
L	12	L35-M0	M	409	35	44	17	1	9m
L	12	L36-M1	M	410	36	44	17	2	9m
L	12	L37-M2	M	411	37	44	17	3	9m
L	12	L38-N0	N	412	38	44	17	4	9m
L	12	L39-N1	N	413	39	44	17	5	9m
L	12	L40-N2	N	414	40	44	17	6	9m

Row	rowIndex	Label	Slice	Speaker Index	grpIndex	Row total	Controller ID	Channel	Cable Length
L	12	L41-O0	O	415	41	44	17	7	10m
L	12	L42-O1	O	416	42	44	17	8	10m
L	12	L43-O2	O	417	43	44	17	9	10m
M	13	M0-B0	B	418	0	45	17	10	10m
M	13	M1-B1	B	419	1	45	17	11	10m
M	13	M2-B2	B	420	2	45	17	12	10m
M	13	M3-C0	C	421	3	45	17	13	9m
M	13	M4-C1	C	422	4	45	17	14	9m
M	13	M5-C2	C	423	5	45	17	15	9m
M	13	M6-D0	D	424	6	45	17	16	9m
M	13	M7-D1	D	425	7	45	17	17	9m
M	13	M8-D2	D	426	8	45	17	18	9m
M	13	M9-D3	D	427	9	45	17	19	9m
M	13	M10-E0	E	428	10	45	17	20	9m
M	13	M11-E1	E	429	11	45	17	21	9m
M	13	M12-E2	E	430	12	45	17	22	9m
M	13	M13-F0	F	431	13	45	17	23	8m
M	13	M14-F1	F	432	14	45	18	0	8m
M	13	M15-F2	F	433	15	45	18	1	8m
M	13	M16-G0	G	434	16	45	18	2	8m
M	13	M17-G1	G	435	17	45	18	3	8m
M	13	M18-G2	G	436	18	45	18	4	8m
M	13	M19-H0	H	437	19	45	18	5	7m
M	13	M20-H1	H	438	20	45	18	6	7m
M	13	M21-H2	H	439	21	45	18	7	7m
M	13	M22-H3	H	440	22	45	18	8	7m
M	13	M23-I0	I	441	23	45	18	9	7m
M	13	M24-I1	I	442	24	45	18	10	7m
M	13	M25-I2	I	443	25	45	18	11	7m
M	13	M26-J0	J	444	26	45	18	12	8m
M	13	M27-J1	J	445	27	45	18	13	8m
M	13	M28-J2	J	446	28	45	18	14	8m
M	13	M29-K0	K	447	29	45	18	15	8m
M	13	M30-K1	K	448	30	45	18	16	8m
M	13	M31-K2	K	449	31	45	18	17	8m
M	13	M32-L0	L	450	32	45	18	18	9m

Row	RowIndex	Label	Slice	Speaker Index	grpIndex	Row total	Controller ID	Channel	Cable Length
M	13	M33-L1	L	451	33	45	18	19	9m
M	13	M34-L2	L	452	34	45	18	20	9m
M	13	M35-M0	M	453	35	45	18	21	9m
M	13	M36-M1	M	454	36	45	18	22	9m
M	13	M37-M2	M	455	37	45	18	23	9m
M	13	M38-M3	M	456	38	45	19	0	9m
M	13	M39-N0	N	457	39	45	19	1	9m
M	13	M40-N1	N	458	40	45	19	2	9m
M	13	M41-N2	N	459	41	45	19	3	9m
M	13	M42-O0	O	460	42	45	19	4	10m
M	13	M43-O1	O	461	43	45	19	5	10m
M	13	M44-O2	O	462	44	45	19	6	10m
N	14	N0-B0	B	463	0	46	19	7	10m
N	14	N1-B1	B	464	1	46	19	8	10m
N	14	N2-B2	B	465	2	46	19	9	10m
N	14	N3-C0	C	466	3	46	19	10	10m
N	14	N4-C1	C	467	4	46	19	11	10m
N	14	N5-C2	C	468	5	46	19	12	10m
N	14	N6-D0	D	469	6	46	19	13	9m
N	14	N7-D1	D	470	7	46	19	14	9m
N	14	N8-D2	D	471	8	46	19	15	9m
N	14	N9-D3	D	472	9	46	19	16	9m
N	14	N10-E0	E	473	10	46	19	17	9m
N	14	N11-E1	E	474	11	46	19	18	9m
N	14	N12-E2	E	475	12	46	19	19	9m
N	14	N13-F0	F	476	13	46	19	20	8m
N	14	N14-F1	F	477	14	46	19	21	8m
N	14	N15-F2	F	478	15	46	19	22	8m
N	14	N16-G0	G	479	16	46	19	23	8m
N	14	N17-G1	G	480	17	46	20	0	8m
N	14	N18-G2	G	481	18	46	20	1	8m
N	14	N19-G3	G	482	19	46	20	2	8m
N	14	N20-H0	H	483	20	46	20	3	8m
N	14	N21-H1	H	484	21	46	20	4	8m
N	14	N22-H2	H	485	22	46	20	5	8m
N	14	N23-I0	I	486	23	46	20	6	8m

Row	RowIndex	Label	Slice	Speaker Index	grpIndex	Row total	Controller ID	Channel	Cable Length
N	14	N24-I1	I	487	24	46	20	7	8m
N	14	N25-I2	I	488	25	46	20	8	8m
N	14	N26-J0	J	489	26	46	20	9	8m
N	14	N27-J1	J	490	27	46	20	10	8m
N	14	N28-J2	J	491	28	46	20	11	8m
N	14	N29-J3	J	492	29	46	20	12	8m
N	14	N30-K0	K	493	30	46	20	13	8m
N	14	N31-K1	K	494	31	46	20	14	8m
N	14	N32-K2	K	495	32	46	20	15	8m
N	14	N33-L0	L	496	33	46	20	16	9m
N	14	N34-L1	L	497	34	46	20	17	9m
N	14	N35-L2	L	498	35	46	20	18	9m
N	14	N36-M0	M	499	36	46	20	19	9m
N	14	N37-M1	M	500	37	46	20	20	9m
N	14	N38-M2	M	501	38	46	20	21	9m
N	14	N39-M3	M	502	39	46	20	22	9m
N	14	N40-N0	N	503	40	46	20	23	10m
N	14	N41-N1	N	504	41	46	21	0	10m
N	14	N42-N2	N	505	42	46	21	1	10m
N	14	N43-O0	O	506	43	46	21	2	10m
N	14	N44-O1	O	507	44	46	21	3	10m
N	14	N45-O2	O	508	45	46	21	4	10m
O	15	O0-B0	B	509	0	45	21	5	10m
O	15	O1-B1	B	510	1	45	21	6	10m
O	15	O2-B2	B	511	2	45	21	7	10m
O	15	O3-C0	C	512	3	45	21	8	10m
O	15	O4-C1	C	513	4	45	21	9	10m
O	15	O5-C2	C	514	5	45	21	10	10m
O	15	O6-D0	D	515	6	45	21	11	9m
O	15	O7-D1	D	516	7	45	21	12	9m
O	15	O8-D2	D	517	8	45	21	13	9m
O	15	O9-D3	D	518	9	45	21	14	9m
O	15	O10-E0	E	519	10	45	21	15	9m
O	15	O11-E1	E	520	11	45	21	16	9m
O	15	O12-E2	E	521	12	45	21	17	9m
O	15	O13-F0	F	522	13	45	21	18	8m

Row	RowIndex	Label	Slice	Speaker Index	grpIndex	Row total	Controller ID	Channel	Cable Length
O	15	O14-F1	F	523	14	45	21	19	8m
O	15	O15-F2	F	524	15	45	21	20	8m
O	15	O16-G0	G	525	16	45	21	21	8m
O	15	O17-G1	G	526	17	45	21	22	8m
O	15	O18-G2	G	527	18	45	21	23	8m
O	15	O19-H0	H	528	19	45	22	0	8m
O	15	O20-H1	H	529	20	45	22	1	8m
O	15	O21-H2	H	530	21	45	22	2	8m
O	15	O22-H3	H	531	22	45	22	3	8m
O	15	O23-I0	I	532	23	45	22	4	8m
O	15	O24-I1	I	533	24	45	22	5	8m
O	15	O25-I2	I	534	25	45	22	6	8m
O	15	O26-J0	J	535	26	45	22	7	8m
O	15	O27-J1	J	536	27	45	22	8	8m
O	15	O28-J2	J	537	28	45	22	9	8m
O	15	O29-K0	K	538	29	45	22	10	8m
O	15	O30-K1	K	539	30	45	22	11	8m
O	15	O31-K2	K	540	31	45	22	12	8m
O	15	O32-L0	L	541	32	45	22	13	9m
O	15	O33-L1	L	542	33	45	22	14	9m
O	15	O34-L2	L	543	34	45	22	15	9m
O	15	O35-M0	M	544	35	45	22	16	9m
O	15	O36-M1	M	545	36	45	22	17	9m
O	15	O37-M2	M	546	37	45	22	18	9m
O	15	O38-M3	M	547	38	45	22	19	9m
O	15	O39-N0	N	548	39	45	22	20	10m
O	15	O40-N1	N	549	40	45	22	21	10m
O	15	O41-N2	N	550	41	45	22	22	10m
O	15	O42-O0	O	551	42	45	22	23	10m
O	15	O43-O1	O	552	43	45	23	0	10m
O	15	O44-O2	O	553	44	45	23	1	10m
P	16	P0-B0	B	554	0	44	23	2	10m
P	16	P1-B1	B	555	1	44	23	3	10m
P	16	P2-B2	B	556	2	44	23	4	10m
P	16	P3-C0	C	557	3	44	23	5	10m
P	16	P4-C1	C	558	4	44	23	6	10m

Row	RowIndex	Label	Slice	Speaker Index	grpIndex	Row total	Controller ID	Channel	Cable Length
P	16	P5-C2	C	559	5	44	23	7	10m
P	16	P6-D0	D	560	6	44	23	8	9m
P	16	P7-D1	D	561	7	44	23	9	9m
P	16	P8-D2	D	562	8	44	23	10	9m
P	16	P9-D3	D	563	9	44	23	11	9m
P	16	P10-E0	E	564	10	44	23	12	9m
P	16	P11-E1	E	565	11	44	23	13	9m
P	16	P12-E2	E	566	12	44	23	14	9m
P	16	P13-F0	F	567	13	44	23	15	8m
P	16	P14-F1	F	568	14	44	23	16	8m
P	16	P15-F2	F	569	15	44	23	17	8m
P	16	P16-G0	G	570	16	44	23	18	8m
P	16	P17-G1	G	571	17	44	23	19	8m
P	16	P18-G2	G	572	18	44	23	20	8m
P	16	P19-H0	H	573	19	44	23	21	8m
P	16	P20-H1	H	574	20	44	23	22	8m
P	16	P21-H2	H	575	21	44	23	23	8m
P	16	P22-I0	I	576	22	44	24	0	8m
P	16	P23-I1	I	577	23	44	24	1	8m
P	16	P24-I2	I	578	24	44	24	2	8m
P	16	P25-J0	J	579	25	44	24	3	8m
P	16	P26-J1	J	580	26	44	24	4	8m
P	16	P27-J2	J	581	27	44	24	5	8m
P	16	P28-K0	K	582	28	44	24	6	8m
P	16	P29-K1	K	583	29	44	24	7	8m
P	16	P30-K2	K	584	30	44	24	8	8m
P	16	P31-L0	L	585	31	44	24	9	9m
P	16	P32-L1	L	586	32	44	24	10	9m
P	16	P33-L2	L	587	33	44	24	11	9m
P	16	P34-M0	M	588	34	44	24	12	9m
P	16	P35-M1	M	589	35	44	24	13	9m
P	16	P36-M2	M	590	36	44	24	14	9m
P	16	P37-M3	M	591	37	44	24	15	9m
P	16	P38-N0	N	592	38	44	24	16	10m
P	16	P39-N1	N	593	39	44	24	17	10m
P	16	P40-N2	N	594	40	44	24	18	10m

Row	rowIndex	Label	Slice	Speaker Index	grpIndex	Row total	Controller ID	Channel	Cable Length
P	16	P41-O0	O	595	41	44	24	19	10m
P	16	P42-O1	O	596	42	44	24	20	10m
P	16	P43-O2	O	597	43	44	24	21	10m
Q	17	Q0-B0	B	598	0	43	24	22	10m
Q	17	Q1-B1	B	599	1	43	24	23	10m
Q	17	Q2-B2	B	600	2	43	25	0	10m
Q	17	Q3-C0	C	601	3	43	25	1	10m
Q	17	Q4-C1	C	602	4	43	25	2	10m
Q	17	Q5-C2	C	603	5	43	25	3	10m
Q	17	Q6-D0	D	604	6	43	25	4	9m
Q	17	Q7-D1	D	605	7	43	25	5	9m
Q	17	Q8-D2	D	606	8	43	25	6	9m
Q	17	Q9-E0	E	607	9	43	25	7	9m
Q	17	Q10-E1	E	608	10	43	25	8	9m
Q	17	Q11-E2	E	609	11	43	25	9	9m
Q	17	Q12-F0	F	610	12	43	25	10	8m
Q	17	Q13-F1	F	611	13	43	25	11	8m
Q	17	Q14-F2	F	612	14	43	25	12	8m
Q	17	Q15-G0	G	613	15	43	25	13	8m
Q	17	Q16-G1	G	614	16	43	25	14	8m
Q	17	Q17-G2	G	615	17	43	25	15	8m
Q	17	Q18-H0	H	616	18	43	25	16	8m
Q	17	Q19-H1	H	617	19	43	25	17	8m
Q	17	Q20-H2	H	618	20	43	25	18	8m
Q	17	Q21-H3	H	619	21	43	25	19	8m
Q	17	Q22-I0	I	620	22	43	25	20	8m
Q	17	Q23-I1	I	621	23	43	25	21	8m
Q	17	Q24-I2	I	622	24	43	25	22	8m
Q	17	Q25-J0	J	623	25	43	25	23	8m
Q	17	Q26-J1	J	624	26	43	26	0	8m
Q	17	Q27-J2	J	625	27	43	26	1	8m
Q	17	Q28-K0	K	626	28	43	26	2	8m
Q	17	Q29-K1	K	627	29	43	26	3	8m
Q	17	Q30-K2	K	628	30	43	26	4	8m
Q	17	Q31-L0	L	629	31	43	26	5	9m
Q	17	Q32-L1	L	630	32	43	26	6	9m

Row	rowIndex	Label	Slice	Speaker Index	grpIndex	Row total	Controller ID	Channel	Cable Length
Q	17	Q33-L2	L	631	33	43	26	7	9m
Q	17	Q34-M0	M	632	34	43	26	8	9m
Q	17	Q35-M1	M	633	35	43	26	9	9m
Q	17	Q36-M2	M	634	36	43	26	10	9m
Q	17	Q37-N0	N	635	37	43	26	11	10m
Q	17	Q38-N1	N	636	38	43	26	12	10m
Q	17	Q39-N2	N	637	39	43	26	13	10m
Q	17	Q40-O0	O	638	40	43	26	14	10m
Q	17	Q41-O1	O	639	41	43	26	15	10m
Q	17	Q42-O2	O	640	42	43	26	16	10m
R	18	R0-B0	B	641	0	42	26	17	10m
R	18	R1-B1	B	642	1	42	26	18	10m
R	18	R2-B2	B	643	2	42	26	19	10m
R	18	R3-C0	C	644	3	42	26	20	10m
R	18	R4-C1	C	645	4	42	26	21	10m
R	18	R5-C2	C	646	5	42	26	22	10m
R	18	R6-D0	D	647	6	42	26	23	9m
R	18	R7-D1	D	648	7	42	27	0	9m
R	18	R8-D2	D	649	8	42	27	1	9m
R	18	R9-E0	E	650	9	42	27	2	9m
R	18	R10-E1	E	651	10	42	27	3	9m
R	18	R11-E2	E	652	11	42	27	4	9m
R	18	R12-F0	F	653	12	42	27	5	8m
R	18	R13-F1	F	654	13	42	27	6	8m
R	18	R14-F2	F	655	14	42	27	7	8m
R	18	R15-G0	G	656	15	42	27	8	8m
R	18	R16-G1	G	657	16	42	27	9	8m
R	18	R17-G2	G	658	17	42	27	10	8m
R	18	R18-H0	H	659	18	42	27	11	8m
R	18	R19-H1	H	660	19	42	27	12	8m
R	18	R20-H2	H	661	20	42	27	13	8m
R	18	R21-I0	I	662	21	42	27	14	8m
R	18	R22-I1	I	663	22	42	27	15	8m
R	18	R23-I2	I	664	23	42	27	16	8m
R	18	R24-J0	J	665	24	42	27	17	8m
R	18	R25-J1	J	666	25	42	27	18	8m

Row	rowIndex	Label	Slice	Speaker Index	grpIndex	Row total	Controller ID	Channel	Cable Length
R	18	R26-J2	J	667	26	42	27	19	8m
R	18	R27-K0	K	668	27	42	27	20	8m
R	18	R28-K1	K	669	28	42	27	21	8m
R	18	R29-K2	K	670	29	42	27	22	8m
R	18	R30-L0	L	671	30	42	27	23	9m
R	18	R31-L1	L	672	31	42	28	0	9m
R	18	R32-L2	L	673	32	42	28	1	9m
R	18	R33-M0	M	674	33	42	28	2	9m
R	18	R34-M1	M	675	34	42	28	3	9m
R	18	R35-M2	M	676	35	42	28	4	9m
R	18	R36-N0	N	677	36	42	28	5	10m
R	18	R37-N1	N	678	37	42	28	6	10m
R	18	R38-N2	N	679	38	42	28	7	10m
R	18	R39-O0	O	680	39	42	28	8	10m
R	18	R40-O1	O	681	40	42	28	9	10m
R	18	R41-O2	O	682	41	42	28	10	10m
S	19	S0-B0	B	683	0	41	28	11	10m
S	19	S1-B1	B	684	1	41	28	12	10m
S	19	S2-B2	B	685	2	41	28	13	10m
S	19	S3-C0	C	686	3	41	28	14	10m
S	19	S4-C1	C	687	4	41	28	15	10m
S	19	S5-C2	C	688	5	41	28	16	10m
S	19	S6-D0	D	689	6	41	28	17	9m
S	19	S7-D1	D	690	7	41	28	18	9m
S	19	S8-D2	D	691	8	41	28	19	9m
S	19	S9-E0	E	692	9	41	28	20	9m
S	19	S10-E1	E	693	10	41	28	21	9m
S	19	S11-E2	E	694	11	41	28	22	9m
S	19	S12-F0	F	695	12	41	28	23	8m
S	19	S13-F1	F	696	13	41	29	0	8m
S	19	S14-F2	F	697	14	41	29	1	8m
S	19	S15-G0	G	698	15	41	29	2	8m
S	19	S16-G1	G	699	16	41	29	3	8m
S	19	S17-G2	G	700	17	41	29	4	8m
S	19	S18-H0	H	701	18	41	29	5	8m
S	19	S19-H1	H	702	19	41	29	6	8m

Row	rowIndex	Label	Slice	Speaker Index	grpIndex	Row total	Controller ID	Channel	Cable Length
S	19	S20-H2	H	703	20	41	29	7	8m
S	19	S21-I0	I	704	21	41	29	8	8m
S	19	S22-I1	I	705	22	41	29	9	8m
S	19	S23-J0	J	706	23	41	29	10	8m
S	19	S24-J1	J	707	24	41	29	11	8m
S	19	S25-J2	J	708	25	41	29	12	8m
S	19	S26-K0	K	709	26	41	29	13	8m
S	19	S27-K1	K	710	27	41	29	14	8m
S	19	S28-K2	K	711	28	41	29	15	8m
S	19	S29-L0	L	712	29	41	29	16	9m
S	19	S30-L1	L	713	30	41	29	17	9m
S	19	S31-L2	L	714	31	41	29	18	9m
S	19	S32-M0	M	715	32	41	29	19	9m
S	19	S33-M1	M	716	33	41	29	20	9m
S	19	S34-M2	M	717	34	41	29	21	9m
S	19	S35-N0	N	718	35	41	29	22	10m
S	19	S36-N1	N	719	36	41	29	23	10m
S	19	S37-N2	N	720	37	41	30	0	10m
S	19	S38-O0	O	721	38	41	30	1	10m
S	19	S39-O1	O	722	39	41	30	2	10m
S	19	S40-O2	O	723	40	41	30	3	10m
T	20	T0-A0	A	724	0	43	30	4	10m
T	20	T1-A1	A	725	1	43	30	5	10m
T	20	T2-B0	B	726	2	43	30	6	10m
T	20	T3-B1	B	727	3	43	30	7	10m
T	20	T4-B2	B	728	4	43	30	8	10m
T	20	T5-C0	C	729	5	43	30	9	10m
T	20	T6-C1	C	730	6	43	30	10	10m
T	20	T7-C2	C	731	7	43	30	11	10m
T	20	T8-D0	D	732	8	43	30	12	9m
T	20	T9-D1	D	733	9	43	30	13	9m
T	20	T10-E0	E	734	10	43	30	14	9m
T	20	T11-E1	E	735	11	43	30	15	9m
T	20	T12-E2	E	736	12	43	30	16	9m
T	20	T13-F0	F	737	13	43	30	17	8m
T	20	T14-F1	F	738	14	43	30	18	8m

Row	RowIndex	Label	Slice	Speaker Index	grpIndex	Row total	Controller ID	Channel	Cable Length
T	20	T15-F2	F	739	15	43	30	19	8m
T	20	T16-G0	G	740	16	43	30	20	8m
T	20	T17-G1	G	741	17	43	30	21	8m
T	20	T18-H0	H	742	18	43	30	22	8m
T	20	T19-H1	H	743	19	43	30	23	8m
T	20	T20-H2	H	744	20	43	31	0	8m
T	20	T21-I0	I	745	21	43	31	1	8m
T	20	T22-I1	I	746	22	43	31	2	8m
T	20	T23-I2	I	747	23	43	31	3	8m
T	20	T24-J0	J	748	24	43	31	4	8m
T	20	T25-J1	J	749	25	43	31	5	8m
T	20	T26-K0	K	750	26	43	31	6	8m
T	20	T27-K1	K	751	27	43	31	7	8m
T	20	T28-K2	K	752	28	43	31	8	8m
T	20	T29-L0	L	753	29	43	31	9	9m
T	20	T30-L1	L	754	30	43	31	10	9m
T	20	T31-L2	L	755	31	43	31	11	9m
T	20	T32-M0	M	756	32	43	31	12	9m
T	20	T33-M1	M	757	33	43	31	13	9m
T	20	T34-N0	N	758	34	43	31	14	10m
T	20	T35-N1	N	759	35	43	31	15	10m
T	20	T36-N2	N	760	36	43	31	16	10m
T	20	T37-O0	O	761	37	43	31	17	10m
T	20	T38-O1	O	762	38	43	31	18	10m
T	20	T39-O2	O	763	39	43	31	19	10m
T	20	T40-P0	P	764	40	43	31	20	10m
T	20	T41-P1	P	765	41	43	31	21	10m
T	20	T42-P2	P	766	42	43	31	22	10m
U	21	U0-A0	A	767	0	41	31	23	10m
U	21	U1-A1	A	768	1	41	32	0	10m
U	21	U2-A2	A	769	2	41	32	1	10m
U	21	U3-B0	B	770	3	41	32	2	10m
U	21	U4-B1	B	771	4	41	32	3	10m
U	21	U5-C0	C	772	5	41	32	4	10m
U	21	U6-C1	C	773	6	41	32	5	10m
U	21	U7-C2	C	774	7	41	32	6	10m

Row	RowIndex	Label	Slice	Speaker Index	grpIndex	Row total	Controller ID	Channel	Cable Length
U	21	U8-D0	D	775	8	41	32	7	9m
U	21	U9-D1	D	776	9	41	32	8	9m
U	21	U10-E0	E	777	10	41	32	9	9m
U	21	U11-E1	E	778	11	41	32	10	9m
U	21	U12-E2	E	779	12	41	32	11	9m
U	21	U13-F0	F	780	13	41	32	12	8m
U	21	U14-F1	F	781	14	41	32	13	8m
U	21	U15-G0	G	782	15	41	32	14	8m
U	21	U16-G1	G	783	16	41	32	15	8m
U	21	U17-G2	G	784	17	41	32	16	8m
U	21	U18-H0	H	785	18	41	32	17	8m
U	21	U19-H1	H	786	19	41	32	18	8m
U	21	U20-H2	H	787	20	41	32	19	8m
U	21	U21-I0	I	788	21	41	32	20	8m
U	21	U22-I1	I	789	22	41	32	21	8m
U	21	U23-J0	J	790	23	41	32	22	8m
U	21	U24-J1	J	791	24	41	32	23	8m
U	21	U25-J2	J	792	25	41	33	0	8m
U	21	U26-K0	K	793	26	41	33	1	8m
U	21	U27-K1	K	794	27	41	33	2	8m
U	21	U28-L0	L	795	28	41	33	3	9m
U	21	U29-L1	L	796	29	41	33	4	9m
U	21	U30-L2	L	797	30	41	33	5	9m
U	21	U31-M0	M	798	31	41	33	6	9m
U	21	U32-M1	M	799	32	41	33	7	9m
U	21	U33-N0	N	800	33	41	33	8	10m
U	21	U34-N1	N	801	34	41	33	9	10m
U	21	U35-N2	N	802	35	41	33	10	10m
U	21	U36-O0	O	803	36	41	33	11	10m
U	21	U37-O1	O	804	37	41	33	12	10m
U	21	U38-P0	P	805	38	41	33	13	10m
U	21	U39-P1	P	806	39	41	33	14	10m
U	21	U40-P2	P	807	40	41	33	15	10m
V	22	V0-A0	A	808	0	38	33	16	10m
V	22	V1-A1	A	809	1	38	33	17	10m
V	22	V2-B0	B	810	2	38	33	18	10m

Row	RowIndex	Label	Slice	Speaker Index	grpIndex	Row total	Controller ID	Channel	Cable Length
V	22	V3-B1	B	811	3	38	33	19	10m
V	22	V4-B2	B	812	4	38	33	20	10m
V	22	V5-C0	C	813	5	38	33	21	10m
V	22	V6-C1	C	814	6	38	33	22	10m
V	22	V7-D0	D	815	7	38	33	23	9m
V	22	V8-D1	D	816	8	38	34	0	9m
V	22	V9-D2	D	817	9	38	34	1	9m
V	22	V10-E0	E	818	10	38	34	2	9m
V	22	V11-E1	E	819	11	38	34	3	9m
V	22	V12-F0	F	820	12	38	34	4	8m
V	22	V13-F1	F	821	13	38	34	5	8m
V	22	V14-G0	G	822	14	38	34	6	8m
V	22	V15-G1	G	823	15	38	34	7	8m
V	22	V16-G2	G	824	16	38	34	8	8m
V	22	V17-H0	H	825	17	38	34	9	8m
V	22	V18-H1	H	826	18	38	34	10	8m
V	22	V19-I0	I	827	19	38	34	11	8m
V	22	V20-I1	I	828	20	38	34	12	8m
V	22	V21-J0	J	829	21	38	34	13	8m
V	22	V22-J1	J	830	22	38	34	14	8m
V	22	V23-J2	J	831	23	38	34	15	8m
V	22	V24-K0	K	832	24	38	34	16	8m
V	22	V25-K1	K	833	25	38	34	17	8m
V	22	V26-L0	L	834	26	38	34	18	9m
V	22	V27-L1	L	835	27	38	34	19	9m
V	22	V28-M0	M	836	28	38	34	20	9m
V	22	V29-M1	M	837	29	38	34	21	9m
V	22	V30-M2	M	838	30	38	34	22	9m
V	22	V31-N0	N	839	31	38	34	23	10m
V	22	V32-N1	N	840	32	38	35	0	10m
V	22	V33-O0	O	841	33	38	35	1	10m
V	22	V34-O1	O	842	34	38	35	2	10m
V	22	V35-O2	O	843	35	38	35	3	10m
V	22	V36-P0	P	844	36	38	35	4	10m
V	22	V37-P1	P	845	37	38	35	5	10m
W	23	W0-A0	A	846	0	35	35	6	10m

Row	rowIndex	Label	Slice	Speaker Index	grpIndex	Row total	Controller ID	Channel	Cable Length
W	23	W1-A1	A	847	1	35	35	7	10m
W	23	W2-B0	B	848	2	35	35	8	10m
W	23	W3-B1	B	849	3	35	35	9	10m
W	23	W4-C0	C	850	4	35	35	10	10m
W	23	W5-C1	C	851	5	35	35	11	10m
W	23	W6-C2	C	852	6	35	35	12	10m
W	23	W7-D0	D	853	7	35	35	13	9m
W	23	W8-D1	D	854	8	35	35	14	9m
W	23	W9-E0	E	855	9	35	35	15	9m
W	23	W10-E1	E	856	10	35	35	16	9m
W	23	W11-F0	F	857	11	35	35	17	8m
W	23	W12-F1	F	858	12	35	35	18	8m
W	23	W13-G0	G	859	13	35	35	19	8m
W	23	W14-G1	G	860	14	35	35	20	8m
W	23	W15-H0	H	861	15	35	35	21	8m
W	23	W16-H1	H	862	16	35	35	22	8m
W	23	W17-H2	H	863	17	35	35	23	8m
W	23	W18-I0	I	864	18	35	36	0	8m
W	23	W19-I1	I	865	19	35	36	1	8m
W	23	W20-J0	J	866	20	35	36	2	8m
W	23	W21-J1	J	867	21	35	36	3	8m
W	23	W22-K0	K	868	22	35	36	4	8m
W	23	W23-K1	K	869	23	35	36	5	8m
W	23	W24-L0	L	870	24	35	36	6	9m
W	23	W25-L1	L	871	25	35	36	7	9m
W	23	W26-M0	M	872	26	35	36	8	9m
W	23	W27-M1	M	873	27	35	36	9	9m
W	23	W28-N0	N	874	28	35	36	10	10m
W	23	W29-N1	N	875	29	35	36	11	10m
W	23	W30-N2	N	876	30	35	36	12	10m
W	23	W31-O0	O	877	31	35	36	13	10m
W	23	W32-O1	O	878	32	35	36	14	10m
W	23	W33-P0	P	879	33	35	36	15	10m
W	23	W34-P1	P	880	34	35	36	16	10m
X	24	X0-A0	A	881	0	32	36	17	10m
X	24	X1-A1	A	882	1	32	36	18	10m

Row	rowIndex	Label	Slice	Speaker Index	grpIndex	Row total	Controller ID	Channel	Cable Length
X	24	X2-B0	B	883	2	32	36	19	10m
X	24	X3-B1	B	884	3	32	36	20	10m
X	24	X4-C0	C	885	4	32	36	21	10m
X	24	X5-C1	C	886	5	32	36	22	10m
X	24	X6-D0	D	887	6	32	36	23	9m
X	24	X7-D1	D	888	7	32	37	0	9m
X	24	X8-E0	E	889	8	32	37	1	9m
X	24	X9-E1	E	890	9	32	37	2	9m
X	24	X10-F0	F	891	10	32	37	3	8m
X	24	X11-F1	F	892	11	32	37	4	8m
X	24	X12-G0	G	893	12	32	37	5	8m
X	24	X13-G1	G	894	13	32	37	6	8m
X	24	X14-H0	H	895	14	32	37	7	8m
X	24	X15-H1	H	896	15	32	37	8	8m
X	24	X16-I0	I	897	16	32	37	9	8m
X	24	X17-I1	I	898	17	32	37	10	8m
X	24	X18-J0	J	899	18	32	37	11	8m
X	24	X19-J1	J	900	19	32	37	12	8m
X	24	X20-K0	K	901	20	32	37	13	8m
X	24	X21-K1	K	902	21	32	37	14	8m
X	24	X22-L0	L	903	22	32	37	15	9m
X	24	X23-L1	L	904	23	32	37	16	9m
X	24	X24-M0	M	905	24	32	37	17	9m
X	24	X25-M1	M	906	25	32	37	18	9m
X	24	X26-N0	N	907	26	32	37	19	10m
X	24	X27-N1	N	908	27	32	37	20	10m
X	24	X28-O0	O	909	28	32	37	21	10m
X	24	X29-O1	O	910	29	32	37	22	10m
X	24	X30-P0	P	911	30	32	37	23	10m
X	24	X31-P1	P	912	31	32	38	0	10m
Y	25	Y0-A0	A	913	0	28	38	1	10m
Y	25	Y1-B0	B	914	1	28	38	2	10m
Y	25	Y2-B1	B	915	2	28	38	3	10m
Y	25	Y3-C0	C	916	3	28	38	4	10m
Y	25	Y4-C1	C	917	4	28	38	5	10m
Y	25	Y5-D0	D	918	5	28	38	6	9m

Row	rowIndex	Label	Slice	Speaker Index	grpIndex	Row total	Controller ID	Channel	Cable Length
Y	25	Y6-D1	D	919	6	28	38	7	9m
Y	25	Y7-E0	E	920	7	28	38	8	9m
Y	25	Y8-F0	F	921	8	28	38	9	8m
Y	25	Y9-F1	F	922	9	28	38	10	8m
Y	25	Y10-G0	G	923	10	28	38	11	8m
Y	25	Y11-G1	G	924	11	28	38	12	8m
Y	25	Y12-H0	H	925	12	28	38	13	8m
Y	25	Y13-H1	H	926	13	28	38	14	8m
Y	25	Y14-I0	I	927	14	28	38	15	8m
Y	25	Y15-J0	J	928	15	28	38	16	8m
Y	25	Y16-J1	J	929	16	28	38	17	8m
Y	25	Y17-K0	K	930	17	28	38	18	8m
Y	25	Y18-K1	K	931	18	28	38	19	8m
Y	25	Y19-L0	L	932	19	28	38	20	9m
Y	25	Y20-M0	M	933	20	28	38	21	9m
Y	25	Y21-M1	M	934	21	28	38	22	9m
Y	25	Y22-N0	N	935	22	28	38	23	10m
Y	25	Y23-N1	N	936	23	28	39	0	10m
Y	25	Y24-O0	O	937	24	28	39	1	10m
Y	25	Y25-O1	O	938	25	28	39	2	10m
Y	25	Y26-P0	P	939	26	28	39	3	10m
Y	25	Y27-P1	P	940	27	28	39	4	10m
Z	26	Z0-A0	A	941	0	24	39	5	10m
Z	26	Z1-B0	B	942	1	24	39	6	10m
Z	26	Z2-B1	B	943	2	24	39	7	10m
Z	26	Z3-C0	C	944	3	24	39	8	10m
Z	26	Z4-C1	C	945	4	24	39	9	10m
Z	26	Z5-D0	D	946	5	24	39	10	10m
Z	26	Z6-E0	E	947	6	24	39	11	10m
Z	26	Z7-E1	E	948	7	24	39	12	10m
Z	26	Z8-F0	F	949	8	24	39	13	10m
Z	26	Z9-G0	G	950	9	24	39	14	10m
Z	26	Z10-G1	G	951	10	24	39	15	10m
Z	26	Z11-H0	H	952	11	24	39	16	10m
Z	26	Z12-I0	I	953	12	24	39	17	10m
Z	26	Z13-J0	J	954	13	24	39	18	10m

Row	rowIndex	Label	Slice	Speaker Index	grpIndex	Row total	Controller ID	Channel	Cable Length
Z	26	Z14-J1	J	955	14	24	39	19	10m
Z	26	Z15-K0	K	956	15	24	39	20	10m
Z	26	Z16-L0	L	957	16	24	39	21	10m
Z	26	Z17-L1	L	958	17	24	39	22	10m
Z	26	Z18-M0	M	959	18	24	39	23	10m
Z	26	Z19-N0	N	960	19	24	40	0	10m
Z	26	Z20-N1	N	961	20	24	40	1	10m
Z	26	Z21-O0	O	962	21	24	40	2	10m
Z	26	Z22-P0	P	963	22	24	40	3	10m
Z	26	Z23-P1	P	964	23	24	40	4	10m
AA	27	AA0-A0	A	965	0	20	40	5	10m
AA	27	AA1-B0	B	966	1	20	40	6	10m
AA	27	AA2-C0	C	967	2	20	40	7	10m
AA	27	AA3-D0	D	968	3	20	40	8	10m
AA	27	AA4-D1	D	969	4	20	40	9	10m
AA	27	AA5-E0	E	970	5	20	40	10	10m
AA	27	AA6-F0	F	971	6	20	40	11	10m
AA	27	AA7-G0	G	972	7	20	40	12	10m
AA	27	AA8-H0	H	973	8	20	40	13	10m
AA	27	AA9-H1	H	974	9	20	40	14	10m
AA	27	AA10-I0	I	975	10	20	40	15	10m
AA	27	AA11-J0	J	976	11	20	40	16	10m
AA	27	AA12-K0	K	977	12	20	40	17	10m
AA	27	AA13-L0	L	978	13	20	40	18	10m
AA	27	AA14-L1	L	979	14	20	40	19	10m
AA	27	AA15-M0	M	980	15	20	40	20	10m
AA	27	AA16-N0	N	981	16	20	40	21	10m
AA	27	AA17-O0	O	982	17	20	40	22	10m
AA	27	AA18-P0	P	983	18	20	40	23	10m
AA	27	AA19-P1	P	984	19	20	41	0	10m
BB	54	BB0-A0	A	985	0	16	41	1	10m
BB	54	BB1-B0	B	986	1	16	41	2	10m
BB	54	BB2-C0	C	987	2	16	41	3	10m
BB	54	BB3-D0	D	988	3	16	41	4	10m
BB	54	BB4-E0	E	989	4	16	41	5	10m
BB	54	BB5-F0	F	990	5	16	41	6	10m

Row	rowIndex	Label	Slice	Speaker Index	grpIndex	Row total	Controller ID	Channel	Cable Length
BB	54	BB6-G0	G	991	6	16	41	7	10m
BB	54	BB7-H0	H	992	7	16	41	8	10m
BB	54	BB8-I0	I	993	8	16	41	9	10m
BB	54	BB9-J0	J	994	9	16	41	10	10m
BB	54	BB10-K0	K	995	10	16	41	11	10m
BB	54	BB11-L0	L	996	11	16	41	12	10m
BB	54	BB12-M0	M	997	12	16	41	13	10m
BB	54	BB13-N0	N	998	13	16	41	14	10m
BB	54	BB14-O0	O	999	14	16	41	15	10m
BB	54	BB15-P0	P	1000	15	16	41	16	10m
CC	81	CC0-A0	A	1001	0	13	41	17	10m
CC	81	CC1-B0	B	1002	1	13	41	18	10m
CC	81	CC2-C0	C	1003	2	13	41	19	10m
CC	81	CC3-E0	E	1004	3	13	41	20	10m
CC	81	CC4-F0	F	1005	4	13	41	21	10m
CC	81	CC5-G0	G	1006	5	13	41	22	10m
CC	81	CC6-H0	H	1007	6	13	41	23	10m
CC	81	CC7-J0	J	1008	7	13	42	0	10m
CC	81	CC8-K0	K	1009	8	13	42	1	10m
CC	81	CC9-L0	L	1010	9	13	42	2	10m
CC	81	CC10-N0	N	1011	10	13	42	3	10m
CC	81	CC11-O0	O	1012	11	13	42	4	10m
CC	81	CC12-P0	P	1013	12	13	42	5	10m
DD	108	DD0-B0	B	1014	0	9	42	6	10m
DD	108	DD1-D0	D	1015	1	9	42	7	10m
DD	108	DD2-F0	F	1016	2	9	42	8	10m
DD	108	DD3-H0	H	1017	3	9	42	9	10m
DD	108	DD4-I0	I	1018	4	9	42	10	10m
DD	108	DD5-K0	K	1019	5	9	42	11	10m
DD	108	DD6-M0	M	1020	6	9	42	12	10m
DD	108	DD7-O0	O	1021	7	9	42	13	10m
DD	108	DD8-P0	P	1022	8	9	42	14	10m
EE	135	EE0-A0	A	1023	0	1	42	15	10m

Controller Patching Information

Speaker Index	Label	Controller ID	Channel
0	A0-C0	0	0
1	A1-C1	0	1
2	A2-D0	0	2
3	A3-E0	0	3
4	A4-E1	0	4
5	A5-F0	0	5
6	A6-G0	0	6
7	A7-G1	0	7
8	A8-H0	0	8
9	A9-H1	0	9
10	A10-I0	0	10
11	A11-J0	0	11
12	A12-J1	0	12
13	A13-K0	0	13
14	A14-L0	0	14
15	A15-L1	0	15
16	A16-M0	0	16
17	A17-N0	0	17
18	A18-N1	0	18
19	B0-B0	0	19
20	B1-C0	0	20
21	B2-C1	0	21
22	B3-D0	0	22
23	B4-D1	0	23
24	B5-E0	1	0
25	B6-E1	1	1
26	B7-F0	1	2
27	B8-G0	1	3
28	B9-G1	1	4
29	B10-H0	1	5
30	B11-H1	1	6
31	B12-I0	1	7
32	B13-I1	1	8
33	B14-J0	1	9

Speaker Index	Label	Controller ID	Channel
34	B15-J1	1	10
35	B16-K0	1	11
36	B17-K1	1	12
37	B18-L0	1	13
38	B19-M0	1	14
39	B20-M1	1	15
40	B21-N0	1	16
41	B22-N1	1	17
42	B23-O0	1	18
43	C0-B0	1	19
44	C1-C0	1	20
45	C2-C1	1	21
46	C3-D0	1	22
47	C4-D1	1	23
48	C5-E0	2	0
49	C6-E1	2	1
50	C7-F0	2	2
51	C8-F1	2	3
52	C9-G0	2	4
53	C10-G1	2	5
54	C11-H0	2	6
55	C12-H1	2	7
56	C13-H2	2	8
57	C14-I0	2	9
58	C15-I1	2	10
59	C16-J0	2	11
60	C17-J1	2	12
61	C18-K0	2	13
62	C19-K1	2	14
63	C20-L0	2	15
64	C21-L1	2	16
65	C22-M0	2	17
66	C23-M1	2	18
67	C24-N0	2	19
68	C25-N1	2	20

Speaker Index	Label	Controller ID	Channel
69	C26-O0	2	21
70	D0-B0	2	22
71	D1-B1	2	23
72	D2-C0	3	0
73	D3-C1	3	1
74	D4-D0	3	2
75	D5-D1	3	3
76	D6-E0	3	4
77	D7-E1	3	5
78	D8-F0	3	6
79	D9-F1	3	7
80	D10-F2	3	8
81	D11-G0	3	9
82	D12-G1	3	10
83	D13-H0	3	11
84	D14-H1	3	12
85	D15-I0	3	13
86	D16-I1	3	14
87	D17-J0	3	15
88	D18-J1	3	16
89	D19-K0	3	17
90	D20-K1	3	18
91	D21-K2	3	19
92	D22-L0	3	20
93	D23-L1	3	21
94	D24-M0	3	22
95	D25-M1	3	23
96	D26-N0	4	0
97	D27-N1	4	1
98	D28-O0	4	2
99	D29-O1	4	3
100	E0-B0	4	4
101	E1-B1	4	5
102	E2-C0	4	6
103	E3-C1	4	7
104	E4-D0	4	8

Speaker Index	Label	Controller ID	Channel
105	E5-D1	4	9
106	E6-D2	4	10
107	E7-E0	4	11
108	E8-E1	4	12
109	E9-F0	4	13
110	E10-F1	4	14
111	E11-F2	4	15
112	E12-G0	4	16
113	E13-G1	4	17
114	E14-H0	4	18
115	E15-H1	4	19
116	E16-H2	4	20
117	E17-I0	4	21
118	E18-I1	4	22
119	E19-J0	4	23
120	E20-J1	5	0
121	E21-K0	5	1
122	E22-K1	5	2
123	E23-K2	5	3
124	E24-L0	5	4
125	E25-L1	5	5
126	E26-M0	5	6
127	E27-M1	5	7
128	E28-M2	5	8
129	E29-N0	5	9
130	E30-N1	5	10
131	E31-O0	5	11
132	E32-O1	5	12
133	F0-B0	5	13
134	F1-B1	5	14
135	F2-C0	5	15
136	F3-C1	5	16
137	F4-C2	5	17
138	F5-D0	5	18
139	F6-D1	5	19
140	F7-D2	5	20

Speaker Index	Label	Controller ID	Channel
141	F8-E0	5	21
142	F9-E1	5	22
143	F10-F0	5	23
144	F11-F1	6	0
145	F12-F2	6	1
146	F13-G0	6	2
147	F14-G1	6	3
148	F15-H0	6	4
149	F16-H1	6	5
150	F17-H2	6	6
151	F18-I0	6	7
152	F19-I1	6	8
153	F20-I2	6	9
154	F21-J0	6	10
155	F22-J1	6	11
156	F23-K0	6	12
157	F24-K1	6	13
158	F25-K2	6	14
159	F26-L0	6	15
160	F27-L1	6	16
161	F28-M0	6	17
162	F29-M1	6	18
163	F30-M2	6	19
164	F31-N0	6	20
165	F32-N1	6	21
166	F33-N2	6	22
167	F34-O0	6	23
168	F35-O1	7	0
169	G0-B0	7	1
170	G1-B1	7	2
171	G2-B2	7	3
172	G3-C0	7	4
173	G4-C1	7	5
174	G5-C2	7	6
175	G6-D0	7	7
176	G7-D1	7	8

Speaker Index	Label	Controller ID	Channel
177	G8-E0	7	9
178	G9-E1	7	10
179	G10-E2	7	11
180	G11-F0	7	12
181	G12-F1	7	13
182	G13-F2	7	14
183	G14-G0	7	15
184	G15-G1	7	16
185	G16-G2	7	17
186	G17-H0	7	18
187	G18-H1	7	19
188	G19-H2	7	20
189	G20-I0	7	21
190	G21-I1	7	22
191	G22-J0	7	23
192	G23-J1	8	0
193	G24-J2	8	1
194	G25-K0	8	2
195	G26-K1	8	3
196	G27-K2	8	4
197	G28-L0	8	5
198	G29-L1	8	6
199	G30-L2	8	7
200	G31-M0	8	8
201	G32-M1	8	9
202	G33-N0	8	10
203	G34-N1	8	11
204	G35-N2	8	12
205	G36-O0	8	13
206	G37-O1	8	14
207	G38-O2	8	15
208	H0-B0	8	16
209	H1-B1	8	17
210	H2-B2	8	18
211	H3-C0	8	19
212	H4-C1	8	20

Speaker Index	Label	Controller ID	Channel
213	H5-D0	8	21
214	H6-D1	8	22
215	H7-D2	8	23
216	H8-E0	9	0
217	H9-E1	9	1
218	H10-E2	9	2
219	H11-F0	9	3
220	H12-F1	9	4
221	H13-F2	9	5
222	H14-G0	9	6
223	H15-G1	9	7
224	H16-G2	9	8
225	H17-H0	9	9
226	H18-H1	9	10
227	H19-H2	9	11
228	H20-I0	9	12
229	H21-I1	9	13
230	H22-I2	9	14
231	H23-J0	9	15
232	H24-J1	9	16
233	H25-J2	9	17
234	H26-K0	9	18
235	H27-K1	9	19
236	H28-K2	9	20
237	H29-L0	9	21
238	H30-L1	9	22
239	H31-L2	9	23
240	H32-M0	10	0
241	H33-M1	10	1
242	H34-M2	10	2
243	H35-N0	10	3
244	H36-N1	10	4
245	H37-O0	10	5
246	H38-O1	10	6
247	H39-O2	10	7
248	I0-B0	10	8

Speaker Index	Label	Controller ID	Channel
249	I1-B1	10	9
250	I2-C0	10	10
251	I3-C1	10	11
252	I4-C2	10	12
253	I5-D0	10	13
254	I6-D1	10	14
255	I7-D2	10	15
256	I8-E0	10	16
257	I9-E1	10	17
258	I10-E2	10	18
259	I11-F0	10	19
260	I12-F1	10	20
261	I13-F2	10	21
262	I14-G0	10	22
263	I15-G1	10	23
264	I16-G2	11	0
265	I17-H0	11	1
266	I18-H1	11	2
267	I19-H2	11	3
268	I20-H3	11	4
269	I21-I0	11	5
270	I22-I1	11	6
271	I23-I2	11	7
272	I24-J0	11	8
273	I25-J1	11	9
274	I26-J2	11	10
275	I27-K0	11	11
276	I28-K1	11	12
277	I29-L0	11	13
278	I30-L1	11	14
279	I31-L2	11	15
280	I32-L3	11	16
281	I33-M0	11	17
282	I34-M1	11	18
283	I35-M2	11	19
284	I36-N0	11	20

Speaker Index	Label	Controller ID	Channel
285	I37-N1	11	21
286	I38-N2	11	22
287	I39-O0	11	23
288	I40-O1	12	0
289	J0-B0	12	1
290	J1-B1	12	2
291	J2-B2	12	3
292	J3-C0	12	4
293	J4-C1	12	5
294	J5-C2	12	6
295	J6-D0	12	7
296	J7-D1	12	8
297	J8-D2	12	9
298	J9-E0	12	10
299	J10-E1	12	11
300	J11-E2	12	12
301	J12-F0	12	13
302	J13-F1	12	14
303	J14-F2	12	15
304	J15-G0	12	16
305	J16-G1	12	17
306	J17-G2	12	18
307	J18-H0	12	19
308	J19-H1	12	20
309	J20-H2	12	21
310	J21-I0	12	22
311	J22-I1	12	23
312	J23-I2	13	0
313	J24-J0	13	1
314	J25-J1	13	2
315	J26-J2	13	3
316	J27-K0	13	4
317	J28-K1	13	5
318	J29-K2	13	6
319	J30-L0	13	7
320	J31-L1	13	8

Speaker Index	Label	Controller ID	Channel
321	J32-L2	13	9
322	J33-M0	13	10
323	J34-M1	13	11
324	J35-M2	13	12
325	J36-N0	13	13
326	J37-N1	13	14
327	J38-N2	13	15
328	J39-O0	13	16
329	J40-O1	13	17
330	J41-O2	13	18
331	K0-B0	13	19
332	K1-B1	13	20
333	K2-B2	13	21
334	K3-C0	13	22
335	K4-C1	13	23
336	K5-C2	14	0
337	K6-D0	14	1
338	K7-D1	14	2
339	K8-D2	14	3
340	K9-E0	14	4
341	K10-E1	14	5
342	K11-E2	14	6
343	K12-F0	14	7
344	K13-F1	14	8
345	K14-F2	14	9
346	K15-G0	14	10
347	K16-G1	14	11
348	K17-G2	14	12
349	K18-H0	14	13
350	K19-H1	14	14
351	K20-H2	14	15
352	K21-H3	14	16
353	K22-I0	14	17
354	K23-I1	14	18
355	K24-I2	14	19
356	K25-J0	14	20

Speaker Index	Label	Controller ID	Channel
357	K26-J1	14	21
358	K27-J2	14	22
359	K28-K0	14	23
360	K29-K1	15	0
361	K30-K2	15	1
362	K31-L0	15	2
363	K32-L1	15	3
364	K33-L2	15	4
365	K34-M0	15	5
366	K35-M1	15	6
367	K36-M2	15	7
368	K37-N0	15	8
369	K38-N1	15	9
370	K39-N2	15	10
371	K40-O0	15	11
372	K41-O1	15	12
373	K42-O2	15	13
374	L0-B0	15	14
375	L1-B1	15	15
376	L2-B2	15	16
377	L3-C0	15	17
378	L4-C1	15	18
379	L5-C2	15	19
380	L6-D0	15	20
381	L7-D1	15	21
382	L8-D2	15	22
383	L9-E0	15	23
384	L10-E1	16	0
385	L11-E2	16	1
386	L12-F0	16	2
387	L13-F1	16	3
388	L14-F2	16	4
389	L15-F3	16	5
390	L16-G0	16	6
391	L17-G1	16	7
392	L18-G2	16	8

Speaker Index	Label	Controller ID	Channel
393	L19-H0	16	9
394	L20-H1	16	10
395	L21-H2	16	11
396	L22-I0	16	12
397	L23-I1	16	13
398	L24-I2	16	14
399	L25-J0	16	15
400	L26-J1	16	16
401	L27-J2	16	17
402	L28-K0	16	18
403	L29-K1	16	19
404	L30-K2	16	20
405	L31-K3	16	21
406	L32-L0	16	22
407	L33-L1	16	23
408	L34-L2	17	0
409	L35-M0	17	1
410	L36-M1	17	2
411	L37-M2	17	3
412	L38-N0	17	4
413	L39-N1	17	5
414	L40-N2	17	6
415	L41-O0	17	7
416	L42-O1	17	8
417	L43-O2	17	9
418	M0-B0	17	10
419	M1-B1	17	11
420	M2-B2	17	12
421	M3-C0	17	13
422	M4-C1	17	14
423	M5-C2	17	15
424	M6-D0	17	16
425	M7-D1	17	17
426	M8-D2	17	18
427	M9-D3	17	19
428	M10-E0	17	20

Speaker Index	Label	Controller ID	Channel
429	M11-E1	17	21
430	M12-E2	17	22
431	M13-F0	17	23
432	M14-F1	18	0
433	M15-F2	18	1
434	M16-G0	18	2
435	M17-G1	18	3
436	M18-G2	18	4
437	M19-H0	18	5
438	M20-H1	18	6
439	M21-H2	18	7
440	M22-H3	18	8
441	M23-I0	18	9
442	M24-I1	18	10
443	M25-I2	18	11
444	M26-J0	18	12
445	M27-J1	18	13
446	M28-J2	18	14
447	M29-K0	18	15
448	M30-K1	18	16
449	M31-K2	18	17
450	M32-L0	18	18
451	M33-L1	18	19
452	M34-L2	18	20
453	M35-M0	18	21
454	M36-M1	18	22
455	M37-M2	18	23
456	M38-M3	19	0
457	M39-N0	19	1
458	M40-N1	19	2
459	M41-N2	19	3
460	M42-O0	19	4
461	M43-O1	19	5
462	M44-O2	19	6
463	N0-B0	19	7
464	N1-B1	19	8

Speaker Index	Label	Controller ID	Channel
465	N2-B2	19	9
466	N3-C0	19	10
467	N4-C1	19	11
468	N5-C2	19	12
469	N6-D0	19	13
470	N7-D1	19	14
471	N8-D2	19	15
472	N9-D3	19	16
473	N10-E0	19	17
474	N11-E1	19	18
475	N12-E2	19	19
476	N13-F0	19	20
477	N14-F1	19	21
478	N15-F2	19	22
479	N16-G0	19	23
480	N17-G1	20	0
481	N18-G2	20	1
482	N19-G3	20	2
483	N20-H0	20	3
484	N21-H1	20	4
485	N22-H2	20	5
486	N23-I0	20	6
487	N24-I1	20	7
488	N25-I2	20	8
489	N26-J0	20	9
490	N27-J1	20	10
491	N28-J2	20	11
492	N29-J3	20	12
493	N30-K0	20	13
494	N31-K1	20	14
495	N32-K2	20	15
496	N33-L0	20	16
497	N34-L1	20	17
498	N35-L2	20	18
499	N36-M0	20	19
500	N37-M1	20	20

Speaker Index	Label	Controller ID	Channel
501	N38-M2	20	21
502	N39-M3	20	22
503	N40-N0	20	23
504	N41-N1	21	0
505	N42-N2	21	1
506	N43-O0	21	2
507	N44-O1	21	3
508	N45-O2	21	4
509	O0-B0	21	5
510	O1-B1	21	6
511	O2-B2	21	7
512	O3-C0	21	8
513	O4-C1	21	9
514	O5-C2	21	10
515	O6-D0	21	11
516	O7-D1	21	12
517	O8-D2	21	13
518	O9-D3	21	14
519	O10-E0	21	15
520	O11-E1	21	16
521	O12-E2	21	17
522	O13-F0	21	18
523	O14-F1	21	19
524	O15-F2	21	20
525	O16-G0	21	21
526	O17-G1	21	22
527	O18-G2	21	23
528	O19-H0	22	0
529	O20-H1	22	1
530	O21-H2	22	2
531	O22-H3	22	3
532	O23-I0	22	4
533	O24-I1	22	5
534	O25-I2	22	6
535	O26-J0	22	7
536	O27-J1	22	8

Speaker Index	Label	Controller ID	Channel
537	O28-J2	22	9
538	O29-K0	22	10
539	O30-K1	22	11
540	O31-K2	22	12
541	O32-L0	22	13
542	O33-L1	22	14
543	O34-L2	22	15
544	O35-M0	22	16
545	O36-M1	22	17
546	O37-M2	22	18
547	O38-M3	22	19
548	O39-N0	22	20
549	O40-N1	22	21
550	O41-N2	22	22
551	O42-O0	22	23
552	O43-O1	23	0
553	O44-O2	23	1
554	P0-B0	23	2
555	P1-B1	23	3
556	P2-B2	23	4
557	P3-C0	23	5
558	P4-C1	23	6
559	P5-C2	23	7
560	P6-D0	23	8
561	P7-D1	23	9
562	P8-D2	23	10
563	P9-D3	23	11
564	P10-E0	23	12
565	P11-E1	23	13
566	P12-E2	23	14
567	P13-F0	23	15
568	P14-F1	23	16
569	P15-F2	23	17
570	P16-G0	23	18
571	P17-G1	23	19
572	P18-G2	23	20

Speaker Index	Label	Controller ID	Channel
573	P19-H0	23	21
574	P20-H1	23	22
575	P21-H2	23	23
576	P22-I0	24	0
577	P23-I1	24	1
578	P24-I2	24	2
579	P25-J0	24	3
580	P26-J1	24	4
581	P27-J2	24	5
582	P28-K0	24	6
583	P29-K1	24	7
584	P30-K2	24	8
585	P31-L0	24	9
586	P32-L1	24	10
587	P33-L2	24	11
588	P34-M0	24	12
589	P35-M1	24	13
590	P36-M2	24	14
591	P37-M3	24	15
592	P38-N0	24	16
593	P39-N1	24	17
594	P40-N2	24	18
595	P41-O0	24	19
596	P42-O1	24	20
597	P43-O2	24	21
598	Q0-B0	24	22
599	Q1-B1	24	23
600	Q2-B2	25	0
601	Q3-C0	25	1
602	Q4-C1	25	2
603	Q5-C2	25	3
604	Q6-D0	25	4
605	Q7-D1	25	5
606	Q8-D2	25	6
607	Q9-E0	25	7
608	Q10-E1	25	8

Speaker Index	Label	Controller ID	Channel
609	Q11-E2	25	9
610	Q12-F0	25	10
611	Q13-F1	25	11
612	Q14-F2	25	12
613	Q15-G0	25	13
614	Q16-G1	25	14
615	Q17-G2	25	15
616	Q18-H0	25	16
617	Q19-H1	25	17
618	Q20-H2	25	18
619	Q21-H3	25	19
620	Q22-I0	25	20
621	Q23-I1	25	21
622	Q24-I2	25	22
623	Q25-J0	25	23
624	Q26-J1	26	0
625	Q27-J2	26	1
626	Q28-K0	26	2
627	Q29-K1	26	3
628	Q30-K2	26	4
629	Q31-L0	26	5
630	Q32-L1	26	6
631	Q33-L2	26	7
632	Q34-M0	26	8
633	Q35-M1	26	9
634	Q36-M2	26	10
635	Q37-N0	26	11
636	Q38-N1	26	12
637	Q39-N2	26	13
638	Q40-O0	26	14
639	Q41-O1	26	15
640	Q42-O2	26	16
641	R0-B0	26	17
642	R1-B1	26	18
643	R2-B2	26	19
644	R3-C0	26	20

Speaker Index	Label	Controller ID	Channel
645	R4-C1	26	21
646	R5-C2	26	22
647	R6-D0	26	23
648	R7-D1	27	0
649	R8-D2	27	1
650	R9-E0	27	2
651	R10-E1	27	3
652	R11-E2	27	4
653	R12-F0	27	5
654	R13-F1	27	6
655	R14-F2	27	7
656	R15-G0	27	8
657	R16-G1	27	9
658	R17-G2	27	10
659	R18-H0	27	11
660	R19-H1	27	12
661	R20-H2	27	13
662	R21-I0	27	14
663	R22-I1	27	15
664	R23-I2	27	16
665	R24-J0	27	17
666	R25-J1	27	18
667	R26-J2	27	19
668	R27-K0	27	20
669	R28-K1	27	21
670	R29-K2	27	22
671	R30-L0	27	23
672	R31-L1	28	0
673	R32-L2	28	1
674	R33-M0	28	2
675	R34-M1	28	3
676	R35-M2	28	4
677	R36-N0	28	5
678	R37-N1	28	6
679	R38-N2	28	7
680	R39-O0	28	8

Speaker Index	Label	Controller ID	Channel
681	R40-O1	28	9
682	R41-O2	28	10
683	S0-B0	28	11
684	S1-B1	28	12
685	S2-B2	28	13
686	S3-C0	28	14
687	S4-C1	28	15
688	S5-C2	28	16
689	S6-D0	28	17
690	S7-D1	28	18
691	S8-D2	28	19
692	S9-E0	28	20
693	S10-E1	28	21
694	S11-E2	28	22
695	S12-F0	28	23
696	S13-F1	29	0
697	S14-F2	29	1
698	S15-G0	29	2
699	S16-G1	29	3
700	S17-G2	29	4
701	S18-H0	29	5
702	S19-H1	29	6
703	S20-H2	29	7
704	S21-I0	29	8
705	S22-I1	29	9
706	S23-J0	29	10
707	S24-J1	29	11
708	S25-J2	29	12
709	S26-K0	29	13
710	S27-K1	29	14
711	S28-K2	29	15
712	S29-L0	29	16
713	S30-L1	29	17
714	S31-L2	29	18
715	S32-M0	29	19
716	S33-M1	29	20

Speaker Index	Label	Controller ID	Channel
717	S34-M2	29	21
718	S35-N0	29	22
719	S36-N1	29	23
720	S37-N2	30	0
721	S38-O0	30	1
722	S39-O1	30	2
723	S40-O2	30	3
724	T0-A0	30	4
725	T1-A1	30	5
726	T2-B0	30	6
727	T3-B1	30	7
728	T4-B2	30	8
729	T5-C0	30	9
730	T6-C1	30	10
731	T7-C2	30	11
732	T8-D0	30	12
733	T9-D1	30	13
734	T10-E0	30	14
735	T11-E1	30	15
736	T12-E2	30	16
737	T13-F0	30	17
738	T14-F1	30	18
739	T15-F2	30	19
740	T16-G0	30	20
741	T17-G1	30	21
742	T18-H0	30	22
743	T19-H1	30	23
744	T20-H2	31	0
745	T21-I0	31	1
746	T22-I1	31	2
747	T23-I2	31	3
748	T24-J0	31	4
749	T25-J1	31	5
750	T26-K0	31	6
751	T27-K1	31	7
752	T28-K2	31	8

Speaker Index	Label	Controller ID	Channel
753	T29-L0	31	9
754	T30-L1	31	10
755	T31-L2	31	11
756	T32-M0	31	12
757	T33-M1	31	13
758	T34-N0	31	14
759	T35-N1	31	15
760	T36-N2	31	16
761	T37-O0	31	17
762	T38-O1	31	18
763	T39-O2	31	19
764	T40-P0	31	20
765	T41-P1	31	21
766	T42-P2	31	22
767	U0-A0	31	23
768	U1-A1	32	0
769	U2-A2	32	1
770	U3-B0	32	2
771	U4-B1	32	3
772	U5-C0	32	4
773	U6-C1	32	5
774	U7-C2	32	6
775	U8-D0	32	7
776	U9-D1	32	8
777	U10-E0	32	9
778	U11-E1	32	10
779	U12-E2	32	11
780	U13-F0	32	12
781	U14-F1	32	13
782	U15-G0	32	14
783	U16-G1	32	15
784	U17-G2	32	16
785	U18-H0	32	17
786	U19-H1	32	18
787	U20-H2	32	19
788	U21-I0	32	20

Speaker Index	Label	Controller ID	Channel
789	U22-I1	32	21
790	U23-J0	32	22
791	U24-J1	32	23
792	U25-J2	33	0
793	U26-K0	33	1
794	U27-K1	33	2
795	U28-L0	33	3
796	U29-L1	33	4
797	U30-L2	33	5
798	U31-M0	33	6
799	U32-M1	33	7
800	U33-N0	33	8
801	U34-N1	33	9
802	U35-N2	33	10
803	U36-O0	33	11
804	U37-O1	33	12
805	U38-P0	33	13
806	U39-P1	33	14
807	U40-P2	33	15
808	V0-A0	33	16
809	V1-A1	33	17
810	V2-B0	33	18
811	V3-B1	33	19
812	V4-B2	33	20
813	V5-C0	33	21
814	V6-C1	33	22
815	V7-D0	33	23
816	V8-D1	34	0
817	V9-D2	34	1
818	V10-E0	34	2
819	V11-E1	34	3
820	V12-F0	34	4
821	V13-F1	34	5
822	V14-G0	34	6
823	V15-G1	34	7
824	V16-G2	34	8

Speaker Index	Label	Controller ID	Channel
825	V17-H0	34	9
826	V18-H1	34	10
827	V19-I0	34	11
828	V20-I1	34	12
829	V21-J0	34	13
830	V22-J1	34	14
831	V23-J2	34	15
832	V24-K0	34	16
833	V25-K1	34	17
834	V26-L0	34	18
835	V27-L1	34	19
836	V28-M0	34	20
837	V29-M1	34	21
838	V30-M2	34	22
839	V31-N0	34	23
840	V32-N1	35	0
841	V33-O0	35	1
842	V34-O1	35	2
843	V35-O2	35	3
844	V36-P0	35	4
845	V37-P1	35	5
846	W0-A0	35	6
847	W1-A1	35	7
848	W2-B0	35	8
849	W3-B1	35	9
850	W4-C0	35	10
851	W5-C1	35	11
852	W6-C2	35	12
853	W7-D0	35	13
854	W8-D1	35	14
855	W9-E0	35	15
856	W10-E1	35	16
857	W11-F0	35	17
858	W12-F1	35	18
859	W13-G0	35	19
860	W14-G1	35	20

Speaker Index	Label	Controller ID	Channel
861	W15-H0	35	21
862	W16-H1	35	22
863	W17-H2	35	23
864	W18-I0	36	0
865	W19-I1	36	1
866	W20-J0	36	2
867	W21-J1	36	3
868	W22-K0	36	4
869	W23-K1	36	5
870	W24-L0	36	6
871	W25-L1	36	7
872	W26-M0	36	8
873	W27-M1	36	9
874	W28-N0	36	10
875	W29-N1	36	11
876	W30-N2	36	12
877	W31-O0	36	13
878	W32-O1	36	14
879	W33-P0	36	15
880	W34-P1	36	16
881	X0-A0	36	17
882	X1-A1	36	18
883	X2-B0	36	19
884	X3-B1	36	20
885	X4-C0	36	21
886	X5-C1	36	22
887	X6-D0	36	23
888	X7-D1	37	0
889	X8-E0	37	1
890	X9-E1	37	2
891	X10-F0	37	3
892	X11-F1	37	4
893	X12-G0	37	5
894	X13-G1	37	6
895	X14-H0	37	7
896	X15-H1	37	8

Speaker Index	Label	Controller ID	Channel
897	X16-I0	37	9
898	X17-I1	37	10
899	X18-J0	37	11
900	X19-J1	37	12
901	X20-K0	37	13
902	X21-K1	37	14
903	X22-L0	37	15
904	X23-L1	37	16
905	X24-M0	37	17
906	X25-M1	37	18
907	X26-N0	37	19
908	X27-N1	37	20
909	X28-O0	37	21
910	X29-O1	37	22
911	X30-P0	37	23
912	X31-P1	38	0
913	Y0-A0	38	1
914	Y1-B0	38	2
915	Y2-B1	38	3
916	Y3-C0	38	4
917	Y4-C1	38	5
918	Y5-D0	38	6
919	Y6-D1	38	7
920	Y7-E0	38	8
921	Y8-F0	38	9
922	Y9-F1	38	10
923	Y10-G0	38	11
924	Y11-G1	38	12
925	Y12-H0	38	13
926	Y13-H1	38	14
927	Y14-I0	38	15
928	Y15-J0	38	16
929	Y16-J1	38	17
930	Y17-K0	38	18
931	Y18-K1	38	19
932	Y19-L0	38	20

Speaker Index	Label	Controller ID	Channel
933	Y20-M0	38	21
934	Y21-M1	38	22
935	Y22-N0	38	23
936	Y23-N1	39	0
937	Y24-O0	39	1
938	Y25-O1	39	2
939	Y26-P0	39	3
940	Y27-P1	39	4
941	Z0-A0	39	5
942	Z1-B0	39	6
943	Z2-B1	39	7
944	Z3-C0	39	8
945	Z4-C1	39	9
946	Z5-D0	39	10
947	Z6-E0	39	11
948	Z7-E1	39	12
949	Z8-F0	39	13
950	Z9-G0	39	14
951	Z10-G1	39	15
952	Z11-H0	39	16
953	Z12-I0	39	17
954	Z13-J0	39	18
955	Z14-J1	39	19
956	Z15-K0	39	20
957	Z16-L0	39	21
958	Z17-L1	39	22
959	Z18-M0	39	23
960	Z19-N0	40	0
961	Z20-N1	40	1
962	Z21-O0	40	2
963	Z22-P0	40	3
964	Z23-P1	40	4
965	AA0-A0	40	5
966	AA1-B0	40	6
967	AA2-C0	40	7
968	AA3-D0	40	8

Speaker Index	Label	Controller ID	Channel
969	AA4-D1	40	9
970	AA5-E0	40	10
971	AA6-F0	40	11
972	AA7-G0	40	12
973	AA8-H0	40	13
974	AA9-H1	40	14
975	AA10-I0	40	15
976	AA11-J0	40	16
977	AA12-K0	40	17
978	AA13-L0	40	18
979	AA14-L1	40	19
980	AA15-M0	40	20
981	AA16-N0	40	21
982	AA17-O0	40	22
983	AA18-P0	40	23
984	AA19-P1	41	0
985	BB0-A0	41	1
986	BB1-B0	41	2
987	BB2-C0	41	3
988	BB3-D0	41	4
989	BB4-E0	41	5
990	BB5-F0	41	6
991	BB6-G0	41	7
992	BB7-H0	41	8
993	BB8-I0	41	9
994	BB9-J0	41	10
995	BB10-K0	41	11
996	BB11-L0	41	12
997	BB12-M0	41	13
998	BB13-N0	41	14
999	BB14-O0	41	15
1000	BB15-P0	41	16
1001	CC0-A0	41	17
1002	CC1-B0	41	18
1003	CC2-C0	41	19
1004	CC3-E0	41	20

Speaker Index	Label	Controller ID	Channel
1005	CC4-F0	41	21
1006	CC5-G0	41	22
1007	CC6-H0	41	23
1008	CC7-J0	42	0
1009	CC8-K0	42	1
1010	CC9-L0	42	2
1011	CC10-N0	42	3
1012	CC11-O0	42	4
1013	CC12-P0	42	5
1014	DD0-B0	42	6
1015	DD1-D0	42	7
1016	DD2-F0	42	8
1017	DD3-H0	42	9
1018	DD4-I0	42	10
1019	DD5-K0	42	11
1020	DD6-M0	42	12
1021	DD7-O0	42	13
1022	DD8-P0	42	14
1023	EE0-A0	42	15

APPENDIX IV - ASSEMBLY OF SPHERE

For **assembly** please refer to installation videos accessible on the artwork webpage: https://www.lozano-hemmer.com/sphere_packing_bach.php for contextualised visual support.

Required tools

Forklift, a gantry crane or a 3 meter long beam above the sphere: for lifting each of the sphere's quarters, one at a time.

At least two lifting slings: to pull and guide the sphere sections.

Stand alone mobile structure: for hanging support of top quarter pieces and mainly to lift the dome to the top of the sphere

4'x8' masonite boards x 6 (4 minimum for underneath the structure): these are placed first to be able to manoeuvre and move the sphere slightly

Cotton gloves: to manipulate all parts while avoiding marking and leaving residues onto surfaces.

Important Notes Before Beginning Assembly

The bottom half of the sphere is assembled without being screwed into the floor. That is the last step.

With the help of 4 to 6 people, it is quite easy to gently move the half sphere around across a hard surface. The room in which the sphere resides typically has carpeting which makes it very difficult to move it around for micro-adjustments once it is in place. That is why it is necessary to place masonite beneath the sphere.

Uncrating

Please keep in mind that the wooden slats have fragile edges and are fragile in general

There are 8 quarters of the sphere and one top part that we call the dome. The 8 pieces are held onto plywood structures. There are 4 parts that contain all the cables which are situated onto dollies.

To take off these quarters, the structures must be tipped over onto the ground, with the piece facing up. The brackets in each 4 corners have small handles that unscrew by hand.





Before placing the quarters onto the ground, it is important to place the masonite boards onto the ground in preparation for installation.





Installing Bottom 4 pieces

It is then important to secure a strap onto the two metal extremities of the top of the quarter to lift it from the plywood structure by using the skyjack. It is secured onto the forklift. On the bottom end, two people hand hold the part until it is vertical. Then, it can be moved onto the masonite.





We recommend beginning with the back bottom quarters containing the cables. Once it is in place, attach it using straps or the blockchain to the tall standalone structure.

Repeat the same process of unpacking and lifting with the front bottom (without speaker cables) part that connects to this back part. This part is attached to the forklift while the other is attached to the large stand alone structure. Bring them together and begin by screwing in the bottom.

The screw inserting and tightening process is to skip 1 one on the first round starting by the bottom and NOT tightening them fully. This lets the pieces fall into place. Then insert the screws into the holes that were skipped, loosely once again. Once all the screws are inserted and loosely fitted, tighten them using the same technique of skipping one hole and then passing through a second time to tighten them all.

These two parts stand alone but it is important to secure them to the standalone structure before taking the front piece off the forklift.

Once you have a back piece and a front piece, add the other back bottom piece and front piece in the same way, always using a forklift to move and the standalone structure to keep them secured. Using the same screwing-in technique, secure the back part first to the two others and finally complete the bottom half with the front part without speakers.

At this point, you now have the bottom of the sphere's structure assembled.

Installing Top 4 pieces

Similar to the bottom pieces, the same steps of tipping over the plywood crates and releasing the extremities of the pieces, they are then lifted up by using straps and the forklift.

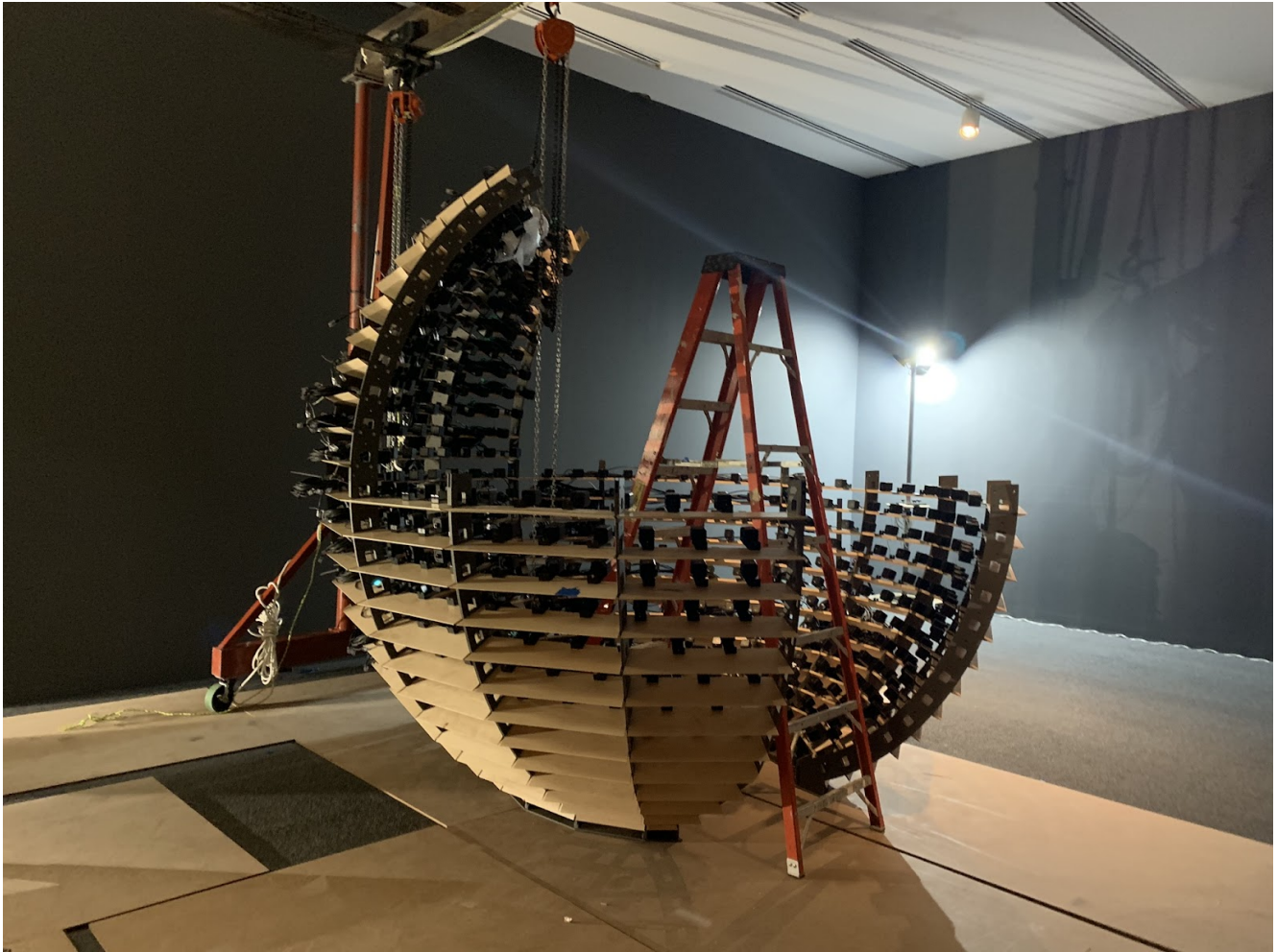



They are then brought over towards the completed structure. Once again, begin with a back quarter that contains a bundle of cables. These are by far the most difficult pieces as they have a heavy load attached to them.

Once you have moved the quarter up by using the forklift and moved it as close as possible to its position, while keeping it attached to the forklift attach it to the stand alone structure. The blockchain will be lifting the parts above the bottom half.

Once it is secured, 2-3 people on the bottom must help lift the structure while another person lifts the part on the blockchain. One person must be on a ladder on the inside of the sphere to help adjust the parts and help them fit within the brackets.





Install the other quarter containing cables and complete the top with the two front parts (without cables) last.

Use the same technique for screwing the sides together.

Dome

It is important to place moving blankets all around the sphere to not damage the wood.

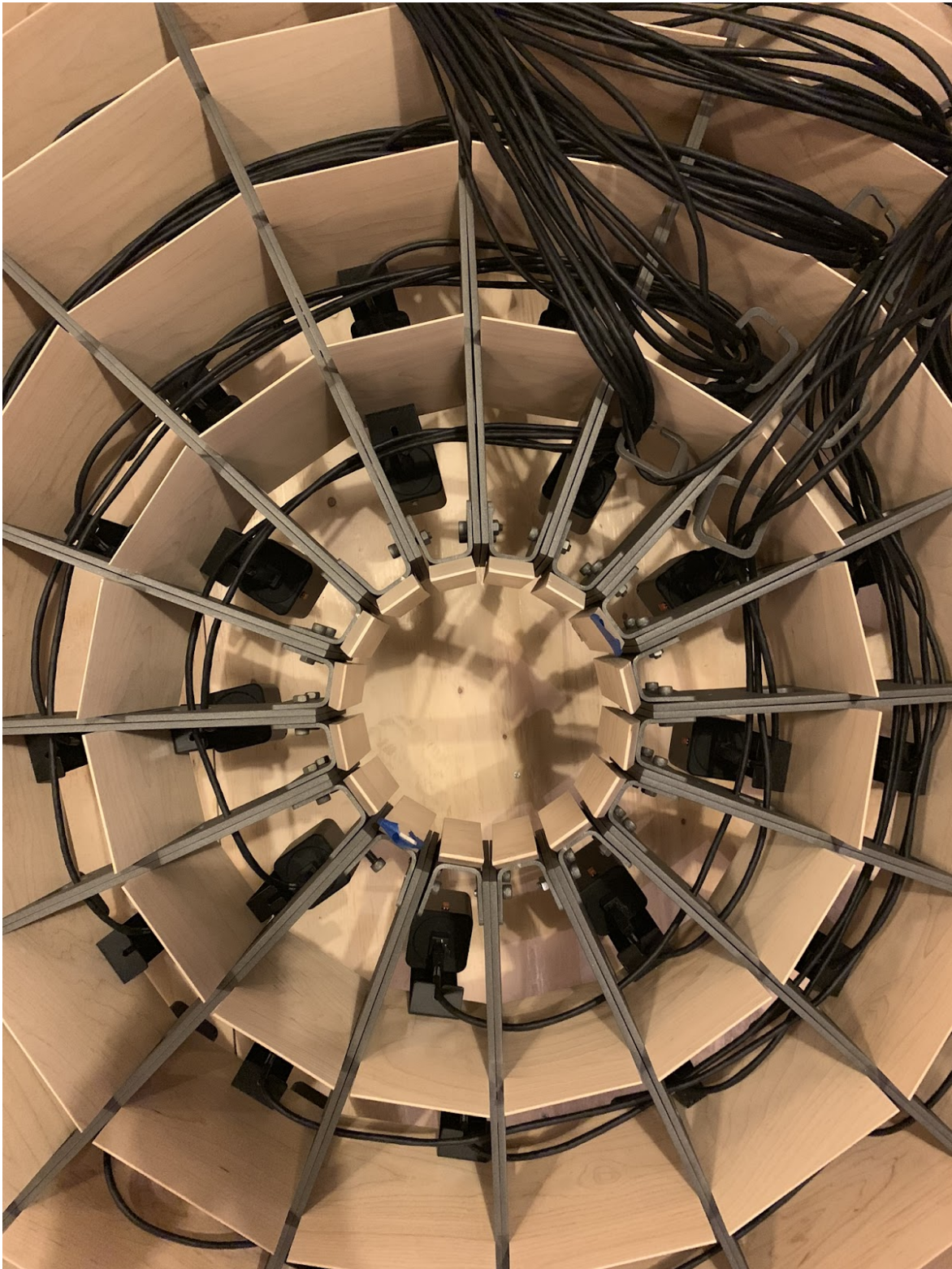

The dome is the last part that needs to be installed onto the structure. It is lifted above the truncated sphere by using the standalone structure.

Place the open crate close to the sphere.

There is a circular plate with an eyelet in the center onto which the blockchain will be installed to lift the dome.



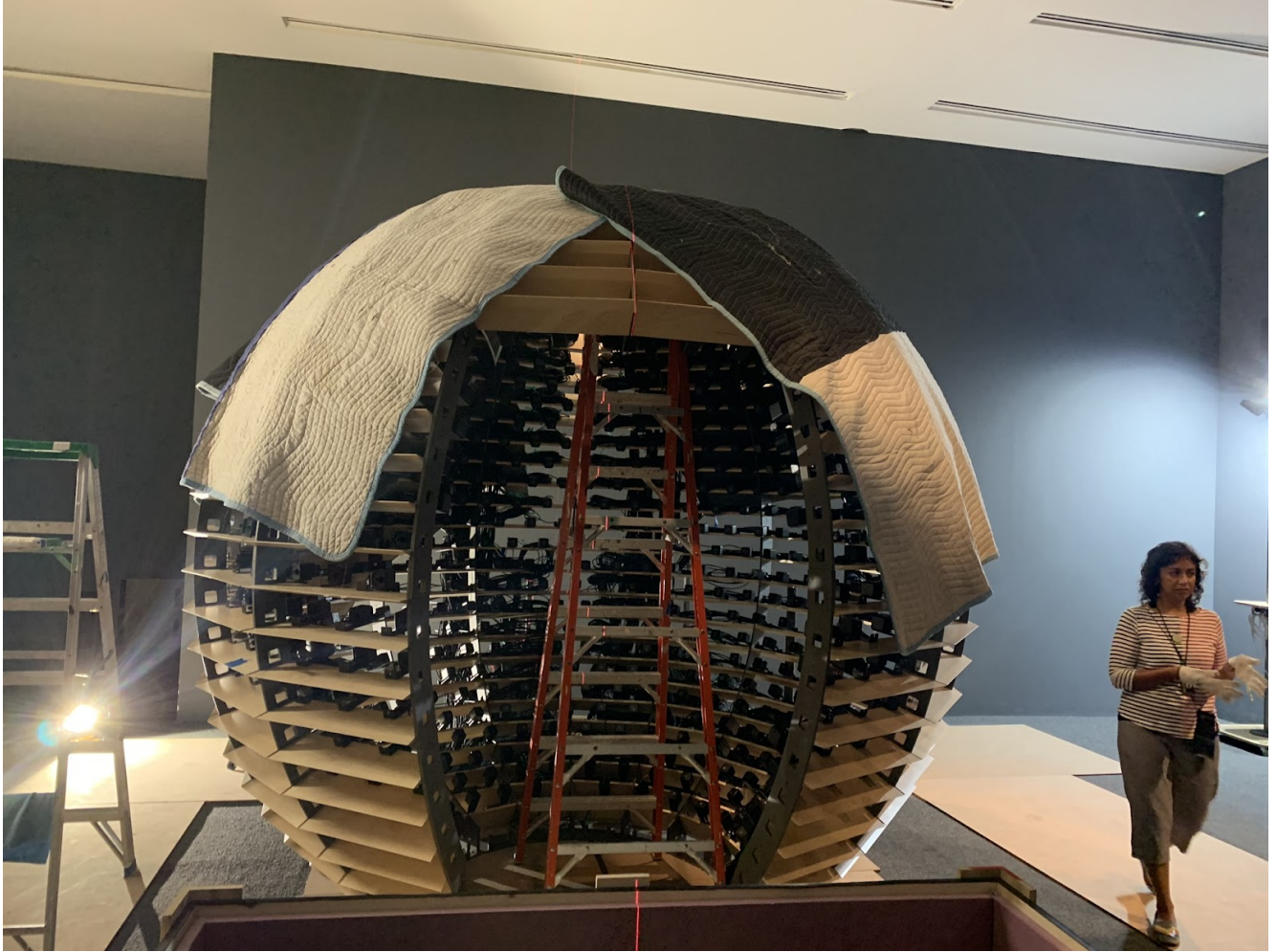

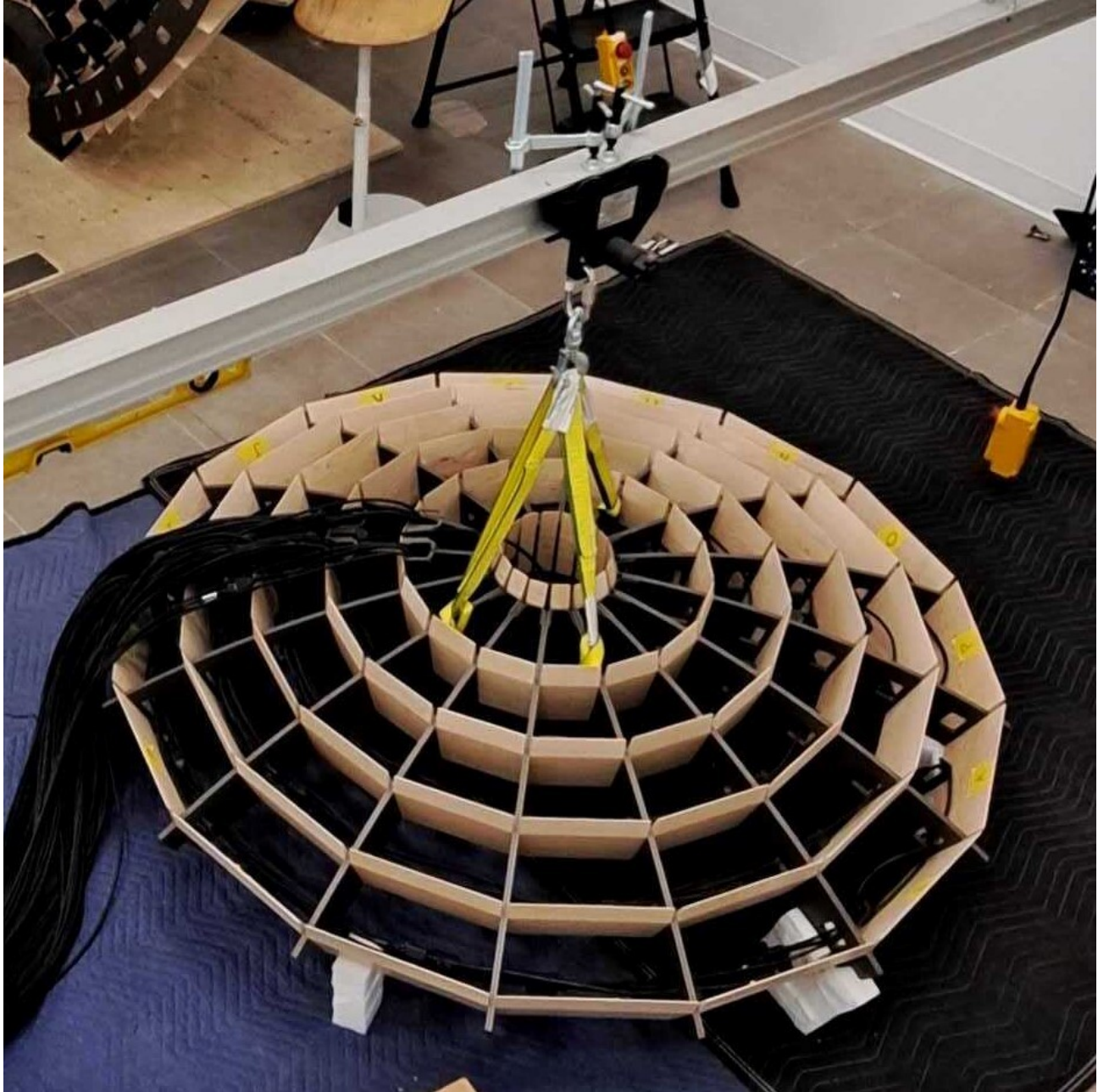



Protect the top of the dome with moving blankets as well.



Lift up the dome using the blockchain, always have 1 person with gloves on each side keeping it in balance.



It is important to attach the cables onto the moving structure as well. They have a significant weight and it is important they do not “scrape” the side of the sphere (fragile wood slats).



Have a person inside the sphere on a ladder that can come and receive the dome and make sure it fits within the brackets. Once it is in position, the person inside the sphere can insert screws loosely, and in the same fashion as for the other parts of the sphere, only tighten every screw once it is in place.

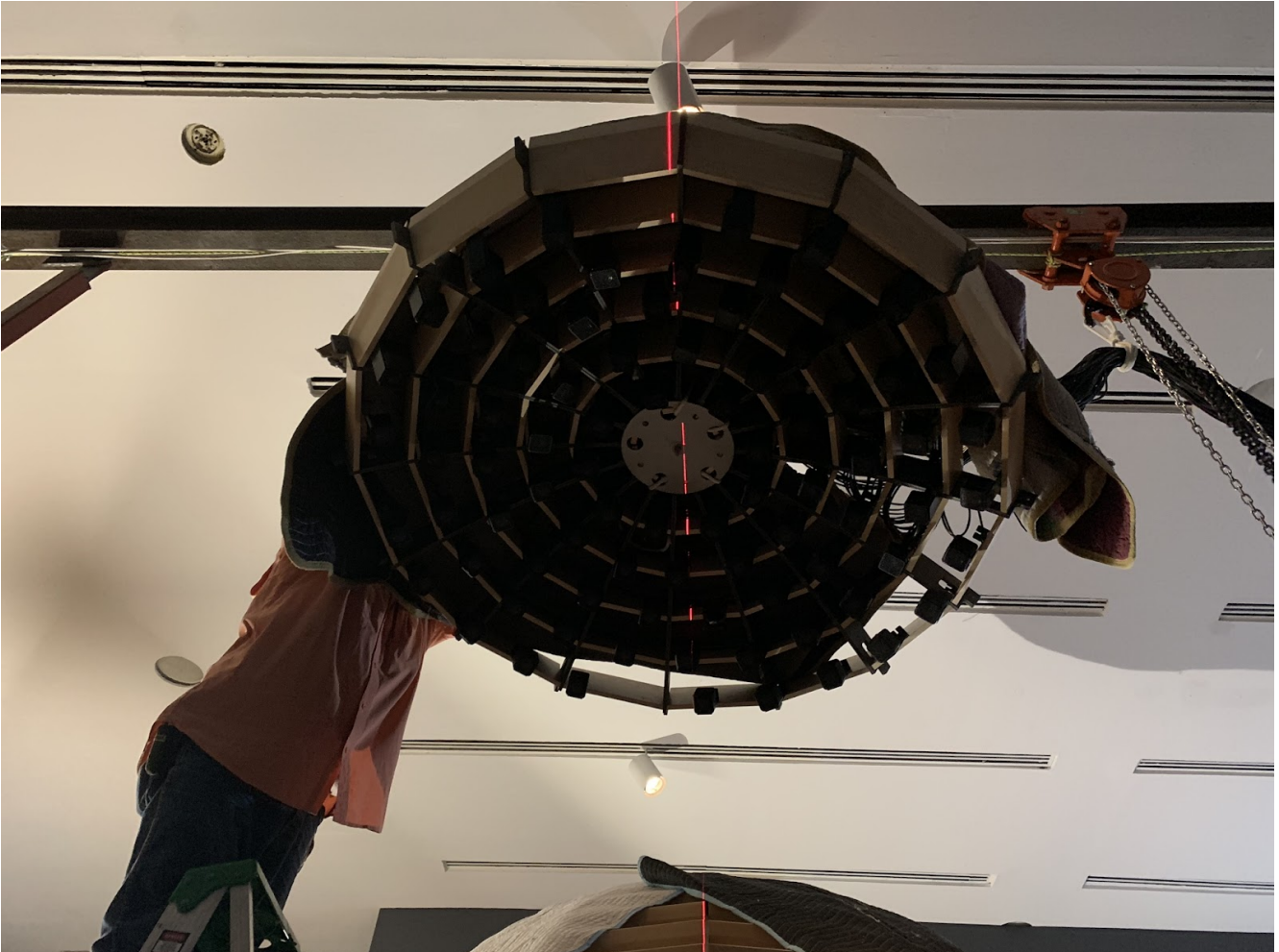

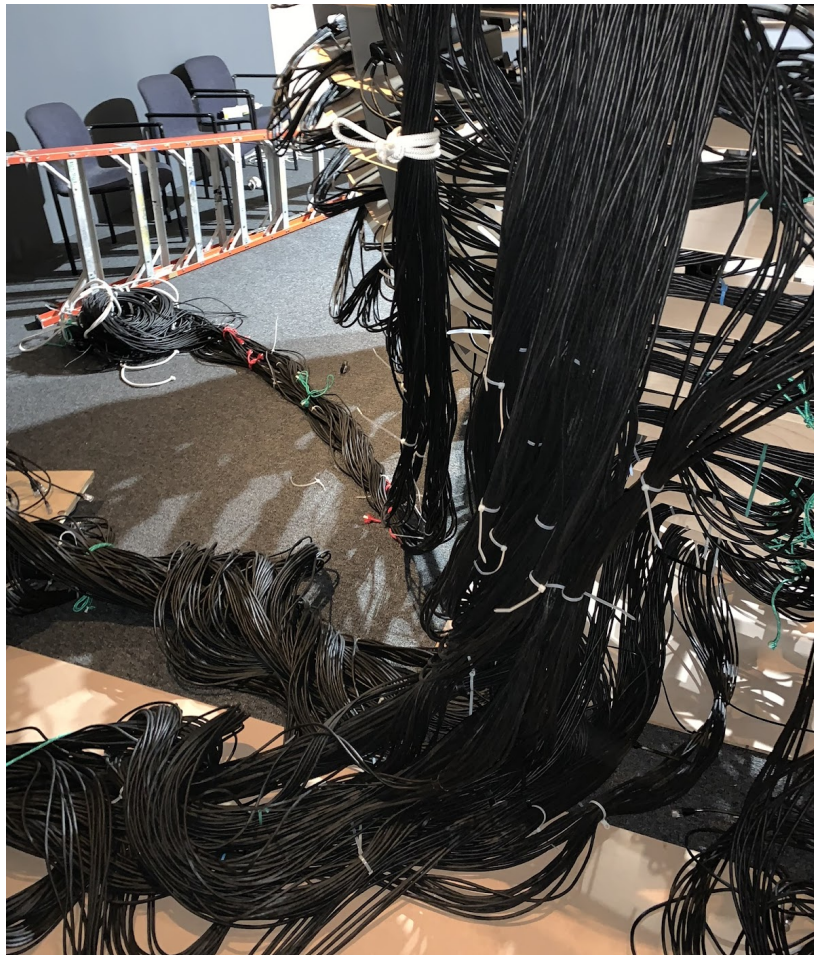

APPENDIX V - DISMANTLING OF SPHERE

Before beginning De-Install

The following tasks should be finished before beginning the actual deinstallation of the sphere

- Cutting small plastic ends to be placed on ethernet cables, 1,024 total. This protects ethernet plastic ends from breaking
- Assembling bundles of braided nylon rope in size groups with their ends heated to prevent fraying. There should be 50+ long and 50+ short ropes. A long rope is 50 cm and a short rope is 25 cm.
- Cut squares of thick 2 in foam, approximately 2,046, one for every exposed wood corner



The above pictures show the foam blocks

Decabling

Never put any weight on the wood slates in any of the following steps.

When unplugging the ethernet cord from a speaker take care to keep your thumb or other finger applying pressure to the ethernet connector. Applying too much force can result in you ripping off the connection. Unplug all of the speakers in a given section before beginning to manage the cables. When working on lower speakers it's best to unplug them from within the sphere.

Begin by unplugging all of the 'front half' of the sphere. Which is the 8 most forward facing slices from both the left and right side.

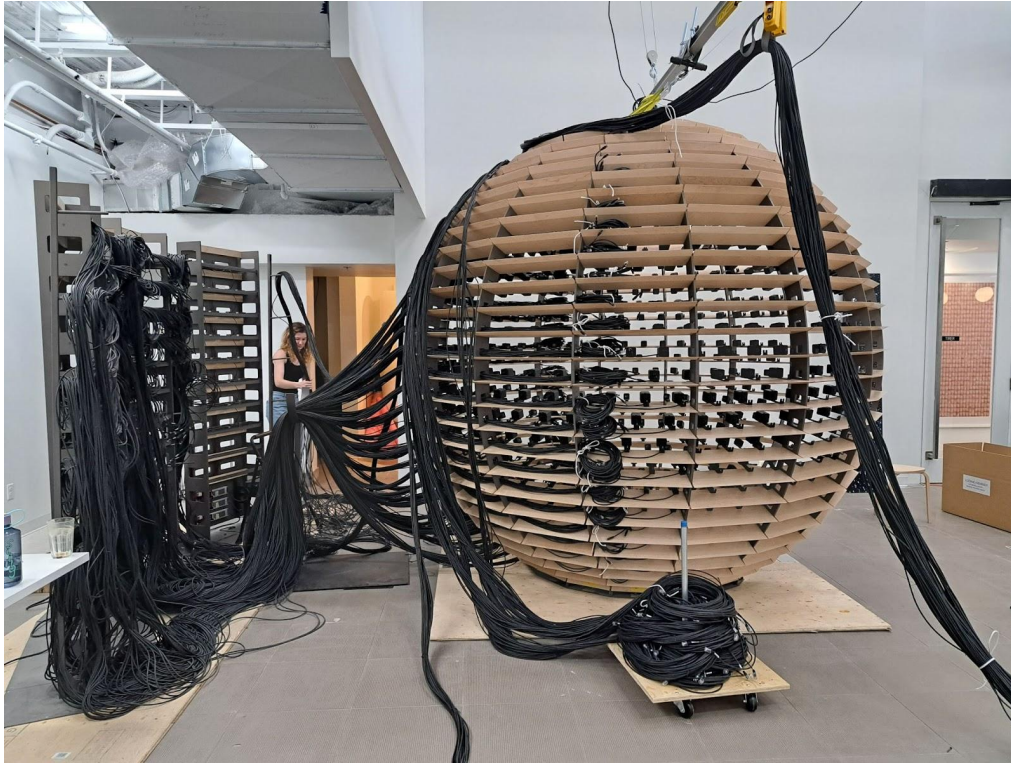

When all of these speakers are unplugged start to thread the ethernet cables through the metal slots. When threading the Ethernet cables out from the speakers take care to not damage the wood or the plugs. Work slowly and carefully. Wrap the cables together and tie them in place by threading one or two pieces of rope through the metal frames as seen in the picture below.



Once the front half of the sphere has all of its speakers unplugged and its cables properly coiled it's time to unplug every cable from the server rack.

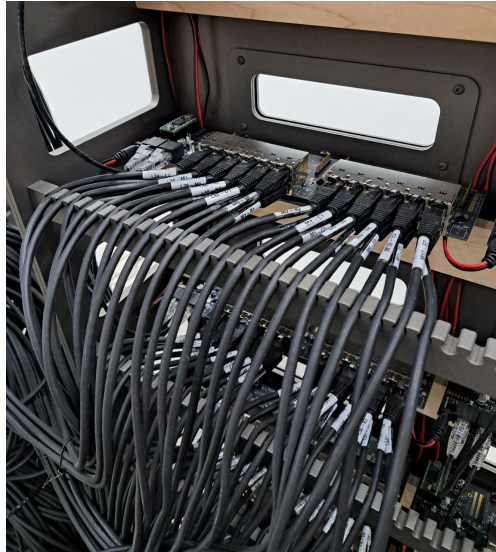

This is what they look like all plugged in.

Start from the far right side of the server rack at the end of the extended alphabet work in reverse alphabetical order. So if you are unplugging cords addressed with M, unplugging cord addressed as L next. Doing things in this order allows us to untangle all the cables effectively as we go.

The first section of the sphere that you should unplug is the dome. Which is addressed from row Z to row EE. When all of the cables are unplugged take time to detangle them, pulling them out into a straight bundle. Go down the bundle trying strings to keep the bundle relatively tightly together. Then take the completed bundle and pull it out of the way. In the picture below this was done with a gantry.

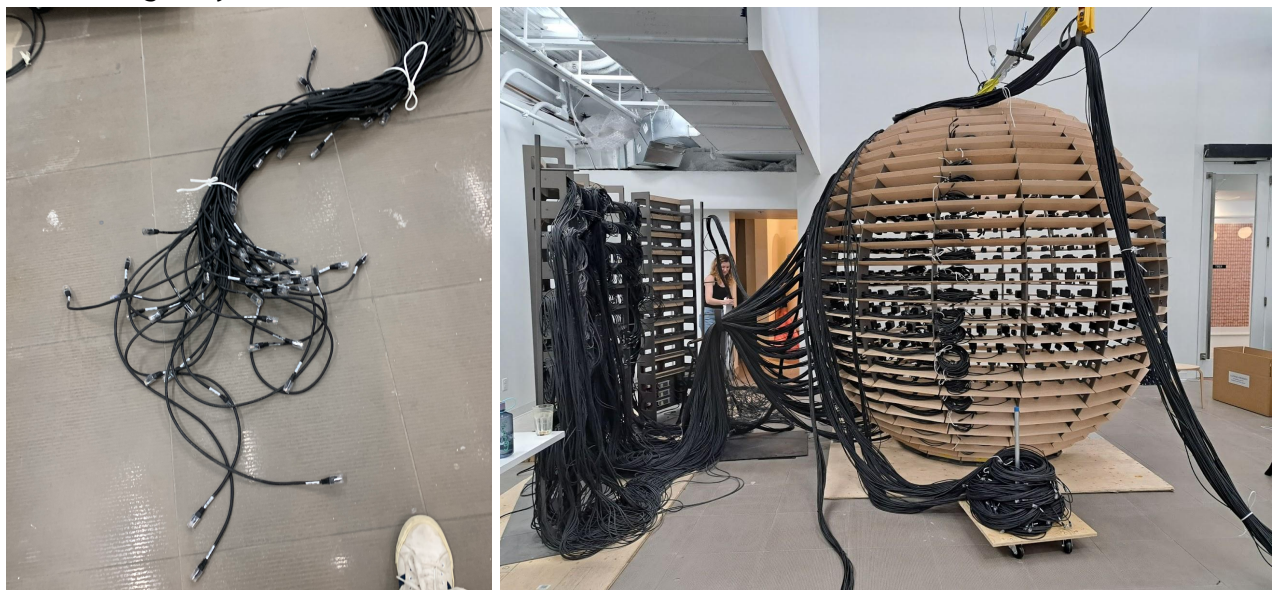

Once it is bundled and out of the way, place the precut caps on the end of each of the RJ45 cables as seen below.

Now that the top of the sphere is handled, begin unplugging all of the cables associated with a row from the server rack. Start at the topmost row, row Y and move downwards onto X, then W, ect.





Once all of the cables for a row are unplugged we need to divide them into two bundles. This is done by tracing them back to the spine of the sphere and parting along their natural routes.

Once the two bundles are identified, go along the length, disentangling as necessary and use rope to tie them together into a relatively tight and straight bundle. Once a bundle is established, put the precut plastic protective ends over all of the cables. Now take your straight bundle and coil it into a circle with a diameter of about a foot-foot and a half, it needs to fit on the dollie without having any edges drag or stick out. Use rope again to tie the coil of each row together as seen below.

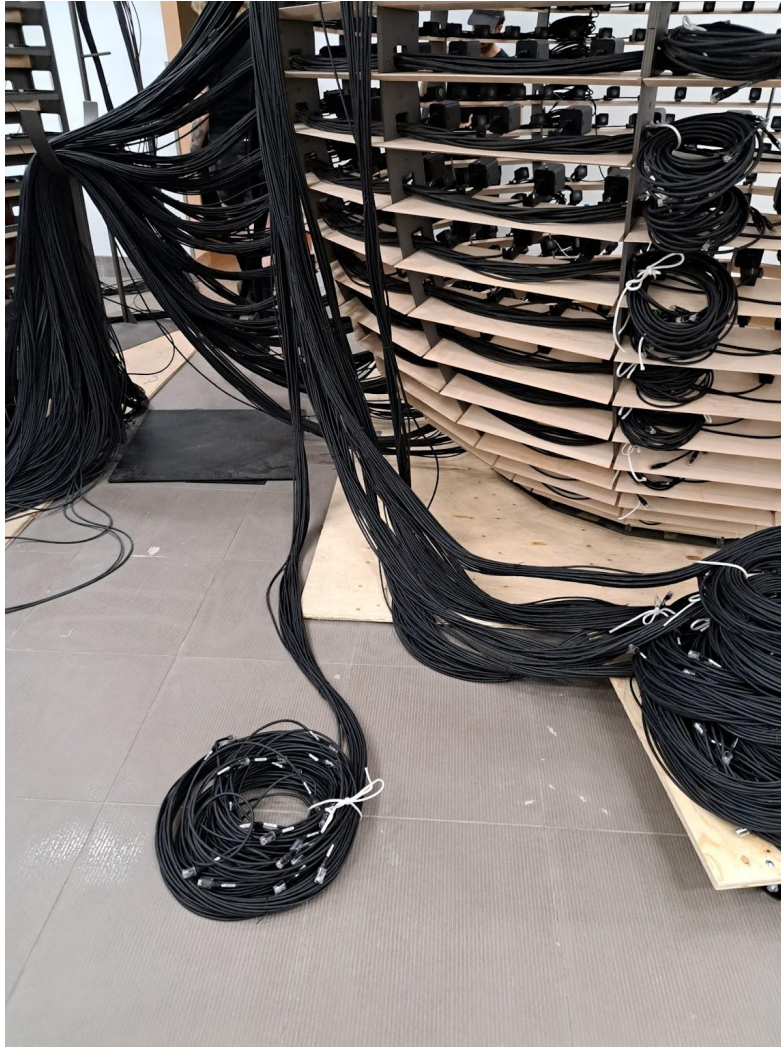

At this point you are done with this row for now, move on to another row until you reach the halfway point of the sphere (Row N addresses). Now place each coil on a side onto the dollie, beginning with the higher row, row Y, and working down to row N. The left and the right side should remain separated in this step and have each of their cables on their own dollie. You will need to leave a bit of slack as shown in the picture above between the cables tied to the slices on the sphere and the dollie to be able to move the dollies around.

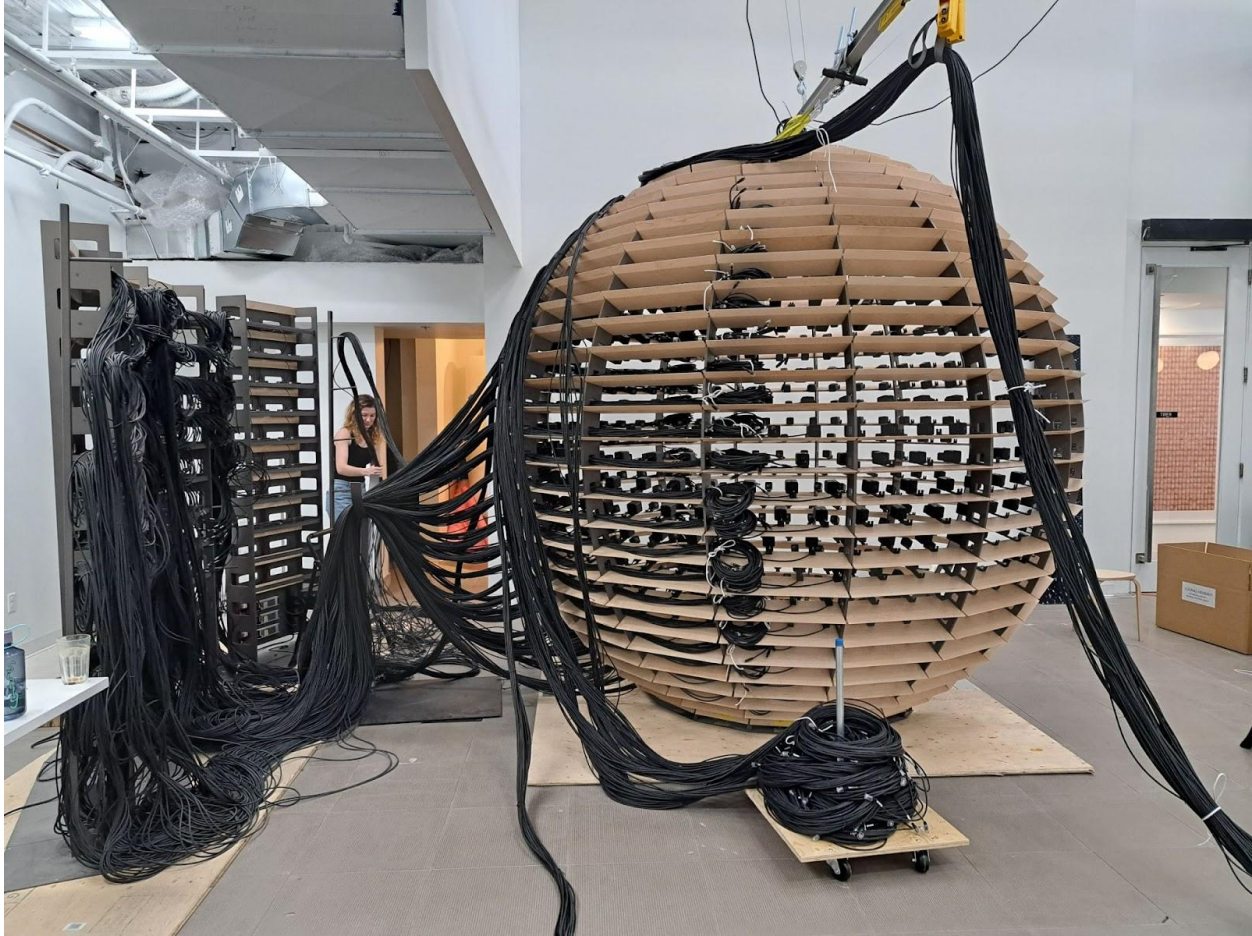

Take great care to ensure that no cables are spilling over the edges of the dollie.

Now that you have prepared the top half of the sphere, return to the server rack and unplug the remaining cables starting at row M and going down to row A. Follow the same steps for preparing a bundle, coiling a bundle and placing them on the dollies. Again take great care to keep the left and right sides separate and to avoid tangling or confusion between the top and bottom cable coils. You should have the dollies clearly labeled to facilitate this.

Disassembling and Rigging

Top Sections

Before you begin rigging anything you will want to set up the four 'leg's' to brace the piece as things are being rigged and lifted.

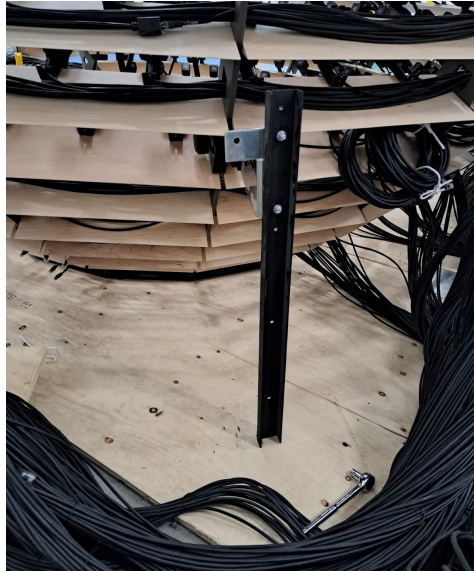

The legs should be positioned carefully as straight as possible on the metal frame around the sphere. The two in the back should be placed between the second and the third metal spline on both sides of the main "spine". The two in the front should both be directly on the second spline on either side of the door. Please see the pictures below for an example.



Now the piece is ready to be rigged.

You will need to start by rigging the top to be lifted. We have used three soft nylon slings and arranged them in choker positions through the square holes. As the piece is being lifted someone can remain inside the sphere and use the slings to do fine control.

Refer to the picture below to see how it was done in the studio and be generous with your weight estimates, the cabling adds a significant amount of weight. The capacity of the studio rig is 1 ton.



Refer to previous pictures for a good example of how the cables of the top part are attached to the gantry.

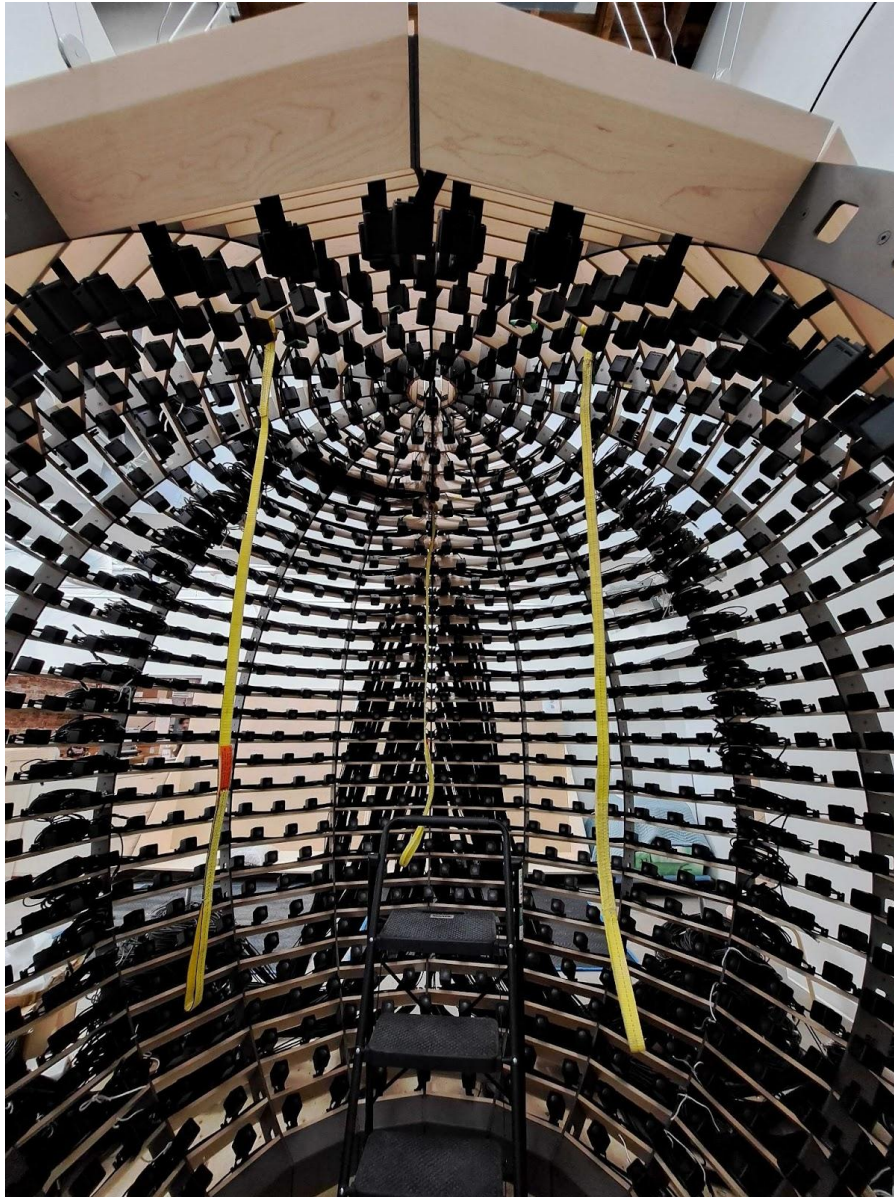

Now that the rig is set up, begin by unscrewing the screws that are holding the top half in place. Store the screws in a jar or similarly secure container.

Now you can safely pull out the top (or hat) of the sphere.

Ideally you would lower the top directly into its appropriate crate. If this is not possible you absolutely cannot rest the piece directly on its speakers. Instead use thick cut foam blocks of about 6 inches tall and rest the metal splices on these blocks. Do not allow the wood to support any weight.



The top is now ready to be packed and can be carried by hand to the crate if necessary.

Right and Left Sections from the Door

The next part to be removed from the sphere is the front top slice to the right or left of the door. Refer to the picture below to see which part we removed first.

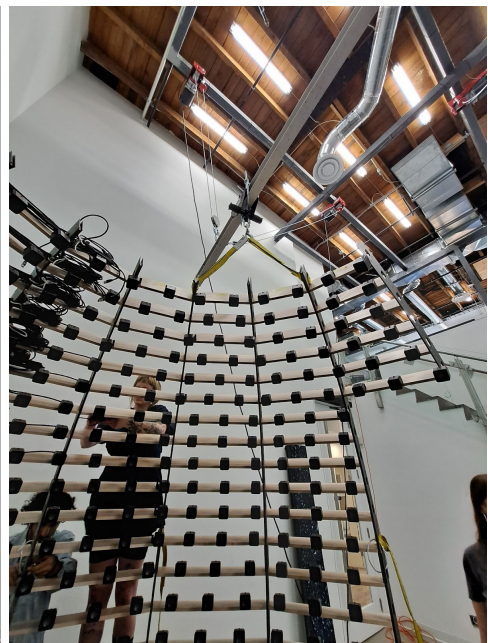
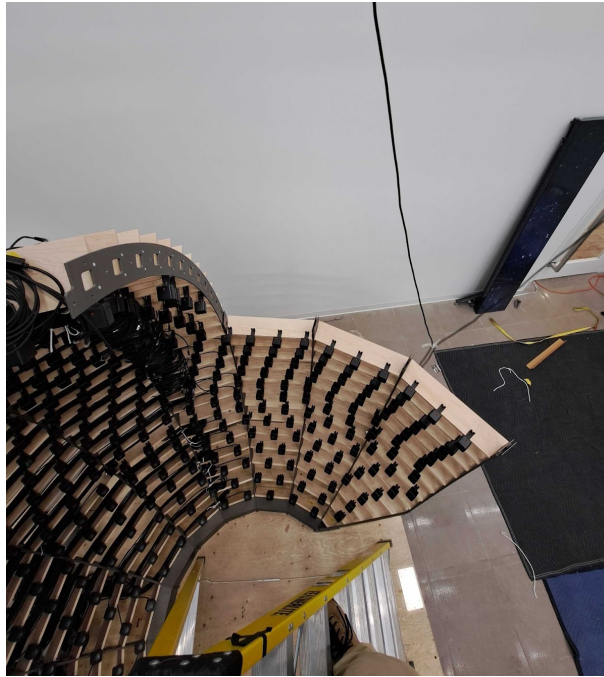

First rig appropriately by attaching two slings to the very top of the section as shown in the pictures above, using the square holes from the metal skeleton. Thread the sling through the square holes: said hole is shown in the following picture.



Next attach two slings to the bottom most row of the section to be removed. One should be at the leftmost point in the row and the other at the rightmost point.



These are used for people to pull so as to apply tension as the slice is unscrewed and lifted. This prevents it from swaying into the sphere and damaging it. Do not neglect this step.

Now use the top rig to apply tension to the slice before unscrewing it from the sphere.

Now unscrew the screws holding the slice in place. The screws holding the sections together will look like those in the picture below. For the top slices on either side of the door you will only need to remove 4 hands for a total of 8 screws. You will also need to unscrew the screws connecting the slice together. There should be 12 total for each slice.



Carefully lift the section off of the rest of the sphere. Remember to have two people applying outward tension to the two slings attached to the bottom of the section so it will not sway back into the sphere.

Lower the section directly into the appropriate crate (placed horizontally on its longer side) or refer to earlier instructions on how to safely place it on Styrofoam blocks on the floor until the crate is ready.

Now that you have one section to the left or right of the door removed, apply these same instructions to the other side and remove it in turn.

Right and Left Sections from the Spine

The next sections to be removed will be the top two sections to the left and right of the spine. In this section you will need to take care to address the large cable bundles. There should be four large bundles each on their separate dollie. When lifting a particular section take care to ensure that its associated bundle is not entangled with any other, and that it is being lifted as the segment is being lifted. so that it does not pull down the sphere.

The picture below shows a general overview of what your sphere will look like.

You can also see some of the measures taken to avoid tangling as you lift the back sections.

During this disassembly a person was physically lifting the relevant bundle of cables, however in future iterations this would ideally be done by rigging it up.

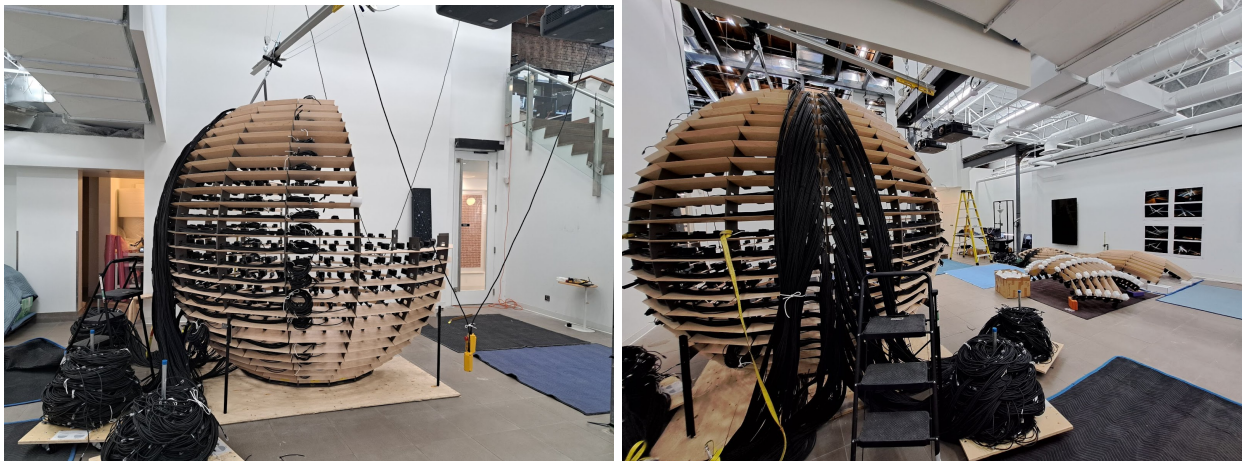

The rest of the instructions for removing these back sections are the same except for the topmost joint of the spine. In this area the hands holding the spine together are also used for cable management. These cables need to be carefully disentangled before unscrewing the hand. Refer to the pictures below for a before and after. NOTE: You will see square brackets for cable management attached all along the spine. DO NOT remove any of these except for the one at the top of the spine. The removed section should look like this.





The rest of the steps to remove the section can be followed the same as previously explained. Be very mindful of the weight the cabling bundle will add.

Bottom Sections

Once you have removed a section to the left or right of the spine repeat for the other side. You should now only have the bottom four sections of the sphere still connected.



The four bottom sections should be individually able to stand. If desired for greater stability and safety you can attach the topmost part of each section to a rig the same way you did for previous sections.

The first thing to do for this section is to remove the attachments to the floor. Refer to the three pictures below. One shows the bottom battens with the cover on. To remove these, unscrew the two screws on the front face. Opening a batton should reveal something like the middle picture. Take care to preserve each face you remove and pack them individually.



Now that the baseboards are removed, pick a side of the door and work one section at a time moving around the sphere clockwise or counterclockwise removing all of the screws holding a single section in place. The bottom sections do not have hands, only screws connecting the metal slices. There should be 13 screws for each section. Because the bottom sections are already on the floor and are relatively light you can lift them safely with 3 people and place them directly in the crate. Take great care when lifting to hold only metal slices. If necessary use slings as handles. If unable to place directly in a crate follow previous instructions for placing on styrofoam blocks or sturdy boxes (with soft sides).





Crating after dismantling the artwork

As seen on the previous pages, it is preferable to store the eight parts of the sphere horizontally, with their shelves facing up. This is also the easiest way to place the sphere back into the dolly crates. Place each crate flipped down on the floor and place the sphere's eight into it, resting on the designed metal brackets. You can then proceed to secure the sphere's eight to the brackets with the provided screws.



APPENDIX VI - REPAIRS AND OTHER MANIPULATIONS

Removing a speaker from a slat

To replace a speaker from a slat, first unplug its ethernet cable. Then, unscrew the speaker bracket from the brass insert wood slat, for this, use a 2.5mm Allen key. Once the bracket is free from the wood slat: the speaker can be unscrewed from the bracket, once again, use the 2.5mm Allen key to unscrew the 2 screws.

To reinstall a speaker to the wood slat, screw back the speaker to the bracket with the two screws, then put the speaker back in position on the sphere and screw the bracket back into the brass insert. Do not over tighten the screw in the brass insert, simply tighten it enough so the speaker does not rotate freely, in order to prevent damage to the wood slat. Finally, plug back the ethernet cable.

Reconditioning a wood slat

The wooden tablets of the sphere are mounted as shown above. Replacing a damaged tablet is quite a laborious process since it requires dismantling a full 1/16 of the sphere. To avoid doing this, if the tablet is only slightly damaged, patching it with wood filler is the best course of action.

Replacing a wood slat

As mentioned in the previous section, replacing a damaged slat is quite a laborious process since it requires dismantling a full slice of the sphere to get access to the screws holding the wood slat in position. It is recommended to get in contact with the studio before going over this process.

The first step consists of ensuring that both the sphere eighth and the slice to be removed are held securely while removing the screws. The slices are connected together with few pairs of square metal plates that align and pressure the slices together in position. Simply disconnect the slice containing an affected wooden slat using an 4mm Allen bit and ratchet tool.

For example, in the scenario described in the following pictures, we strapped the sphere eighth to its crate and had two people hold the slice to be removed. It is important to avoid directly touching the wood slats; instead, hold onto the metal components while wearing cotton gloves.

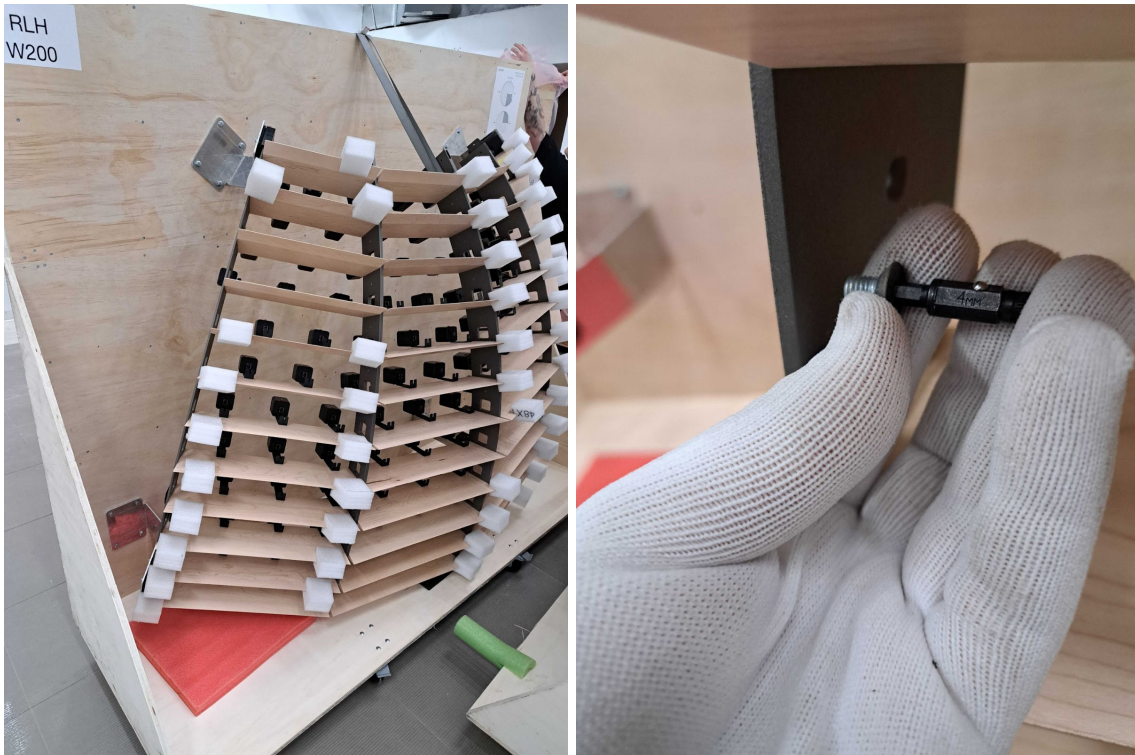



Next, gently place the slice on its back, ensuring it rests on the provided foam cubes. It is crucial to avoid applying additional weight to the part to prevent damage to other wooden slats.

Proceed by removing the four screws that secure the affected slat using the Phillips head bit provided in the bit set. Ensure to hold onto the slat with cotton gloves to prevent it from accidentally falling or slipping during the removal process.



Each row of the sphere contains a different model of slat and each individual slats has unique speaker anchoring hole positions. Consequently, the provided spare slats do not have their brass inserts or holes premade.

This process should be carried out by a professional woodworker using the provided drill bit and a drill press. The drill bit has a specific shape to prevent chipping the wood. Care should be taken to only drill the holes deep enough for the inserts to sit flush with the surface of the slat.

Copy the hole positions from the slat that needs to be replaced onto the new slat: be diligent about the speakers positions as some speakers have straight brackets, while others have right or left offsets, as illustrated below.



Insert the brass inserts into the newly drilled holes. This can be done by using the provided push rod in the drill press chuck. Ensure that the inserts are pushed in securely and flush with the surface of the slat.



Carefully attach the speakers to the corresponding positions on the new slats, ensuring that their positions remain the same as before.



Mount the new wooden slat back onto the metal slice in the sphere, following the same process as when it was initially removed. Take care not to overtighten the wood screws, as excessive force might damage the slat.

Once the wooden slat is securely in place, assemble the metal slice back into the sphere part using the same method as when it was removed. Pay attention to avoid stripping or cross threading any of the screws in the metal. Damaging the powder coating on the metal during repairs can be challenging to fix. Therefore, exercise caution while handling and fastening the screws.

Fixing a Ethernet cable RJ45 hook clip

If the plastic clip on an Ethernet cable breaks off, the cable could be either replaced or a quick fix would be to use an RJ clip. This is a plastic piece that is added to the connector and allows a secure connection again. These clips may not have been provided with the artwork. If you acquire some, please purchase black ones to avoid affecting the aesthetic of the artwork.

Broken RJ45 Connector



Fix it with an rjclip!



APPENDIX VII - CRATES AND PACKING

In this section, you will retrieve information about the provided crates, their content and some details about how they got packed. In case of any discrepancies between the following list of content and the packing list, the packing list prevails.

The crates containing the sphere eights (RLH-W198 to RLH-W205) have been built the same way. Pink antistatic plastic is wrapped around the inner part of the crates to prevent dust and dirt from accumulating. In order to make this more easily removable we created a tape handle. This was made using the following steps.

1. Put down a piece of green masking tape directly on the wood where a handle is desired.
2. Place a line of masking tape over these pieces of tape spanning the length of the partial crate.
3. Put hot glue on this masking tape and use that to seal the plastic.
4. Over the plastic place another piece of green tape and connect it in part to the exposed green tape from the first step.

The pictures below show more detail about this typical crate construction. The foam bumpers are also affixed to the front of the crate using masking tape and hot glue.





Crate RLH-W198

Type: Wood crate on wheels

Content: Sphere's lower right side front eight, near the door

Crate RLH-W199

Type: Wood crate on wheels

Content: Sphere's lower left side front eight, near the door

Crate RLH-W200

Type: Wood crate on wheels

Content: Sphere's upper left side front eight, near the door

Crate RLH-W201

Type: Wood crate on wheels

Content: Sphere's upper right side front eight, near the door

Crate RLH-W202

Type: Wood crate on wheels

Content: Sphere's lower left side back eight, near the server rack. Accompanied by a dollie holding the lower left quarter of the sphere.

Crate RLH-W203

Type: Wood crate on wheels

Content: Sphere's lower right side back eight, near the server rack. Accompanied by a dollie holding the lower right quarter of the sphere.

Crate RLH-W204

Type: Wood crate on wheels

Content: Sphere's upper right side back eight, near the server rack. Accompanied by a dollie holding the upper right quarter of the sphere.

Crate RLH-W205

Type: Wood crate on wheels

Content: Sphere's upper left side back eight, near the server rack. Accompanied by a dollie holding the upper left quarter of the sphere.

Crate RLH-W206

Type: Wooden crate

Content: Sphere's dome picture:



Crate RLH-W207

Type: Wooden crate

Content: The 3 patchbays with their electronic components.

picture:



Crate RLH-W208

Type: Wooden crate

Content: Hardware, electronics, spare components, and misc parts.

picture:

